



# MODEL K

## Installation, Operation, Maintenance, and Storage Manual



**VISIT US AT**

**[www.WILFLEY.com](http://www.WILFLEY.com)**



## TABLE OF CONTENTS

SAFETY PRECAUTIONS.....	1
GENERAL DESCRIPTION AND THEORY OF OPERATION.....	2
INSTALLATION AND START-UP INSTRUCTIONS.....	2
RECOMMENDED SUMP SIZES FOR MAXIMUM CAPACITIES.....	3
GENERAL SERVICE AND MAINTENANCE.....	4
GENERAL INSTRUCTIONS FOR ORDERING PARTS.....	5
MODEL K ASSEMBLY PROCEDURES.....	5
To Assemble Intake Chamber On Frame Base (6SB).....	5
To Assemble Intake Chamber (6SA).....	5
To Assemble Bearing Unit (13).....	5
To Assemble Check Valve Assembly (27).....	5
To Assemble Bearing Unit Into Intake Chamber.....	6
To Assemble wetted parts.....	6
To Assemble Crane Assembly (37).....	6
(3K through 8K Pumps Only).....	6
To Assemble Discharge Keeper Assembly.....	7
KBA PUMP ASSEMBLY PROCEDURE.....	7
Expeller Unit Assembly.....	7
Pump Assembly.....	8
Disassembly.....	8
KBA EXPELLER AND CHECK VALVE UNITS.....	8
INSTALLATION PROCEDURE FOR KBA PACKAGE EXPELLER UNIT.....	9
MODEL K PARTS LIST AND SECTIONAL VIEW.....	10
QUICK CHANGE FEATURES.....	11
MODEL K TRASH PUMP.....	11
METAL PUMPING PARTS – ONE PIECE RUNNER.....	11
METAL PUMPING PARTS – TWO PIECE RUNNER.....	12
RUBBER LINED CASE, REPLACEABLE LINER TYPE.....	12
MANUALLY RUBBER LINED CASE.....	12
CHECK VALVE ASSEMBLY (27).....	13
CRANE ASSEMBLY (37) USED ON 3K THROUGH 8K ONLY.....	13
EXPELLER DEFLECTOR RING (62) – 8K ONLY.....	14
INTAKE SPOOL (1" THROUGH 2½" PUMPS ONLY) BLIND FLANGE ON ALL SIZES.....	14
DISCHARGE KEEPER ASSEMBLY (33) FOR 1K THROUGH 5K ONLY.....	15
DISCHARGE KEEPER SLIP JOINT ASSEMBLY (33CA) FOR 6K AND 8K ONLY.....	15
(YOKE TYPE).....	15
DISCHARGE KEEPER SLIP JOINT ASSEMBLY (33CA) FOR 6K AND 8K ONLY.....	16
(DRAWBOLT TYPE).....	16
BEARING UNIT ASSEMBLY (13).....	16
MODEL KBA PUMP (SPECIAL EXPELLER PACKAGE) (64).....	17
MODEL KH PUMP (WETTED-END).....	18
MODEL K CORROSION AND ABRASION RESISTANT PUMP.....	19
(WETTED-END).....	19
GUARDS, FIXTURES, AND COUPLINGS.....	19
DIRECT DRIVEN PUMP COUPLING GUARD.....	20
DIRECT DRIVEN PUMP COUPLING (44).....	20
OVERHEAD FIXTURE ASSEMBLY (60) AND DRIVE GUARD ASSEMBLY (60AA).....	21
TROUBLE SHOOTING GUIDE.....	22



## **SAFETY PRECAUTIONS**

### **Special Services**

Your Wilfley K pumps may be returned to the factory, at any time, for complete overhaul and repair. Each pump is completely disassembled and worn or inoperable parts are replaced. All rebuilt pumps are subjected to the same testing procedures as newly constructed units.

For more information on rebuilding, contact A.R. Wilfley and Sons, Inc.  
1-303-779-1777

Like all machinery, centrifugal pumps can be dangerous if used improperly. Any of the following misuses may result in a pump that does not function properly. A pump that does not function properly may be a hazard and could cause damage or injury.

For maximum safety and reliability, use only factory supplied parts and closely follow all maintenance and operating recommendations and instructions.

Do not change the pumping conditions or installations of a Wilfley pump without consulting A.R. Wilfley & Sons, Inc. first to ascertain if the pump is capable of handling the new conditions and/or fluid. It is not possible to list all the conceivable misuses. Therefore, the following list is not meant to be complete and is provided only as a guide of the types of misuse that can damage a pump and cause injury. The list will also give a good idea of the kinds of misuses that will void any and all warranties.

1. Do not run a pump with the discharge valve closed.
2. Do not run a pump in the reverse direction.
3. Do not start a pump that is "wind-milling" in the reverse direction due to fluid flowing back down the discharge pipe.
4. Do not continue to operate a pump when there are indications that something is rubbing, binding or knocking.
5. Do not continue to run a pump that gives an indication of overheating.

6. Do not operate a pump with the coupling guard removed. Make sure the guard fits snugly around the coupling so there are no openings.
7. Do not operate a pump if the governor weights are of different sizes.
8. Do not operate a pump that is vibrating, surging, or making abnormal noise.
9. Do not work on a pump unless the drive system is locked out and the pump is disconnected from the drive system.
10. Do not connect the pump to the drive system without first checking to see that the drive system is running in the correct direction.
11. Do not rely on the factory's alignment of the pump and the drive system. Alignment may have changed during shipment.
12. Do not change the pumping conditions or installation of a Wilfley pump without consulting A.R. Wilfley & Sons, Inc. first to ascertain if the pump is capable of handling the new conditions and/or fluid.
13. Do not put a cold liquid in or on a hot pump or a hot liquid in or on a cold pump.
14. Do not hit a pump with any object.
15. Do not use worn or faulty parts.
16. Do not stick hands, arms, legs or any other object into the discharge, suction or any other opening of a pump.
17. Do not weld attachments to the pump.
18. Do not apply external heat to the pump.
19. Do not lift the pump by its case only.
20. Do not examine a pump without using proper eye and face protection.
21. Some materials deteriorate with time. If your pump has been out of service for more than 3 months, please contact A.R. Wilfley & Sons, Inc. for information concerning its suitability for service.



## GENERAL DESCRIPTION AND THEORY OF OPERATION

### Features

The Wilfley Model K is a horizontal mounted, seal-less (no packing, water glands, or mechanical seals), single stage, rear intake centrifugal pump designed to handle corrosive and abrasive slurries.

Incorporated as an integral part of the Runner is an expeller that creates a hydraulic seal which prevents leakage out along the shaft while the pump is operating, eliminating the need for packing or mechanical seals. A simple governor mechanism (Check Valve) opens centrifugally and closes under coil spring pressure to prevent leakage at shutdown and eliminate rubbing contact while pump is operating.

Wetted parts are available in many materials if construction including White Iron, Ni-hard #4, Maxalloy 2, Rubber Neoprene and other synthetic elastomers and Stainless Steels.

Quick change of wear parts is possible without disturbing intake or discharge piping because of the rear intake, the Discharge Keeper Assembly, and the Crane Arm Assembly.

An external Draw Bolt is used to maintain proper clearances and pump efficiency.

The Model K is available in sizes from 1" to 16" discharge and is supplied in three types of drives: overhead V-belt, direct driven and horizontal V-belt driven.

### Advantages

The pump has non-suction characteristics that provide for:

- Suction throttling and capacity control (that reduces vari-speed requirements)
- A lower probability for air trapping.
- A greater surge capacity.
- Ability to handle frothy slurries.

The pump can be fitted with a back flush or dump system.

The wear parts that can be changed quickly without disturbing either intake or discharge piping.

Intake piping can be bolted to either intake flange without loss of efficiency.

### Benefits to you

Wilfley's unique design with heavy-duty construction, packingless characteristic and quick-change features can save operation dollars. You will realize less downtime for maintenance, no product loss or dilution, and true trouble-free operation all of which can maximize profits by lowering the cost of labor and operation. In addition, Wilfley provides a life-time engineering service for your pump. Anytime you have operating or maintenance problems or need to change the pump applications in anyway, Wilfley is ready to help you.

## INSTALLATION AND START-UP INSTRUCTIONS

1. Use Wilfley pump only for the specific application for which it was sold and in the manner prescribed by A.R. Wilfley and Sons, Inc. Wilfley pumps operate with the fluid pumped open to (in contact with) the atmosphere. Use added precautions (and appropriate safe-guards) when handling volatile, inflammable or toxic fluids to prevent venting of fumes without adequate ventilation.
2. The Wilfley slurry pump has no suction and, therefore, must be set below the supply so that the material to be pumped will flow into it by gravity. A hopper bottom, intake sump or tank should be provided. Intake pipe form sump should slope and be as short as possible. Do not pump from one pump directly into a second pump, but provide an intake sump for each pump.
3. The pump should be securely bolted down on a solid, vibration-free, non-flexible foundation and the shaft should be level. Bolting down ordinarily will not distort the bearing alignment. Allow ample room for changing of pump parts because these parts are sometimes very heavy. Support the piping independently and be sure to consider thermal expansion and loading.



4. All flanges are 125# American Standard. The discharge line should have sufficient spring to allow the discharge keeper to be raised about one half inch.
5. Intake pipe may be connected to either or both sides of the pump and need not be disturbed to change the pumping parts or the bearing unit.
6. Provide valves close to the pump in both intake and discharge lines when intake of pump is connected directly to a high tank and in all cement or clay slurry installations.
7. Direction of rotation is counterclockwise when looking at the case. **CHECK ROTATION OF THE DRIVE SYSTEM WITH THE COUPLING OR BELT DRIVE DISCONNECTED FROM THE PUMP STARTING THE PUMP BACKWARDS WILL CAUSE DAMAGE TO THE INTERNAL PARTS.**
8. Rotate pump by hand. There should be some drag due to the Check Valve being engaged. If unable to rotate the pump, check Wear Adjustment section per instruction number 2.
9. Check oil level by looking at oil level sight glass located on both sides of the pump. If level is below the middle of sight glass, fill with SAE 20 non-detergent oil. Do not overfill because oil will leak out along shaft if level is too high.
10. On direct driven pumps check the alignment between the pump and the drive system.
11. Use proper eye and face protection when examining adjusting, maintaining or in any other way working with a pump. Operate the pump with the guard firmly attached. Read all instruction tags on the pump. Stand at a safe distance during start-up.
12. Outside corrosion may damage the pump. Protect pump from corrosive materials.
13. Use only factory supplied spare parts. Pumps need periodic maintenance. Replace worn or faulty parts and keep moving parts appropriately clean and oiled or greased. Use the appropriate tool for any given operation.

14. The Willey pump must be correctly speeded for the proper functioning of the centrifugal seal and check valve. Ask the engineering department at A.R. Willey and Sons, Inc. If you have any questions or problems concerning operation, maintenance, application or anything else concerning your Willey pump. A good reference book to have is published by the Hydraulic Institute and is titled "Hydraulic Institute Standards." 122 E. 42<sup>nd</sup> Street, NY, NY, 10017.

## RECOMMENDED SUMP SIZES FOR MAXIMUM CAPACITIES

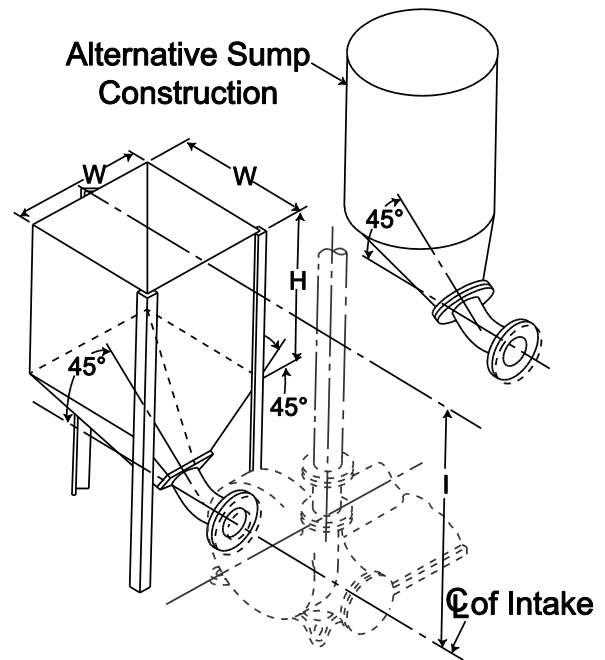

		SUMP DIMENSIONS									
Pump Size	1 & 1.5	2 & 2.5	3	4	5	6	8	10	12	14	16
W (Inches)	18	24	30	36	48	60	72	84	132	150	190
					42 Min	48 Min	60 Min	75 Min	120 Min		
H (Inches)	30	36	42	48	54	66	72	84	84	96	108
								75 Min	75 Min		
I (Inches)	46	57	68	79	96	118	135	166	166	192	210
					90 Min	106 Min	123 Min	150 Min	150 Min		



## GENERAL SERVICE AND MAINTENANCE

### Lubrication

1. Use 300 second viscosity turbine oil or SAE 20.
2. Keep oil level to the middle of sight glass. Do not overfill.
3. After running the pump for one week, drain and fill with new oil.

### Acceptable Oils

<b>Chevron</b>	GTS oil 68
<b>Exxon</b>	Teresstic EP 68
<b>Gulf</b>	Gulf Harmony 68
<b>Mobil</b>	Mobil DTE26 300 SSU 100°F (38°C)
<b>Phillips</b>	Mangus Oil Grad 315
<b>Phillips</b>	MM motor oil SAE 20-20W

### Lubricating Oil Requirements

	Process Liquid Temp. < 300°F	Process Liquid Temp. > 300°F
<b>ISO Grade</b>	VG 68	VG 100
<b>Approx. SSU at 100°F (38°C)</b>	300	470
<b>DIN 51517</b>	C68	C100
<b>Kinem. viscosity at 105°F (40.6°C) in mm<sup>2</sup>/sec</b>	68	100

### Wear Adjustment

1. This adjustment controls the clearance between the runner and the follower plate and takes care of any drop in efficiency or capacity caused by wear.

**CAUTION: Never adjust the clearance while pump is running.**

2. To make this adjustment: loosen outer Draw Bolt Nut; move the bearing unit and Runner as a unit to rear of pump by turning inner Draw Bolt Nut until the Runner touches the Follower Plate; back off 1/4" turn and lock in position by tightening Outer Draw Bolt Nut.
3. Rubber parts should be adjusted during installation Readjustment is seldom needed.

**CAUTION: Never adjust the clearance of rubber parts while pump is running.**

4. Excessive wear to metal parts will result from adjustments made too often. As a general rule adjust clearance not more than four times during the life of the follower plate.
5. All adjustments should be made while turning pump over by hand. Caution would be taken not to rotate in wrong direction.
6. Every time pump is re-assembled, the Follower Plate Gasket (3A) should be replaced.

### Periodic Servicing

The following table contains recommended service checks that should be performed on a periodic basis.

### Recommended Service Checks

	At Install	After First Start-Up	Every Wk	Every Mo	Every 3 Mo.
<b>Flow, Pressure, Temp. (a)</b>		X	X		
<b>Visual (b)</b>		X	X		
<b>Noise Vibration</b>		X	X		
<b>Oil Level</b>	X	X	X		
<b>Oil Change</b>					X

- Flow, Pressure, and Temperature:** All flow, pressure and temperature gauges should be monitored to ensure that the pump is operating within specified limits. If the frame temperatures are monitored, this temperature generally should not exceed 160°F (71.1°C).
- Visual:** Periodic visual inspection should be made of the pump and its installation.

This inspection should include the following:

1. All mounting supports should be secure.
2. All external nuts, bolts and fittings should be tight.



3. All suction and discharge piping should be secure.
4. All surfaces and joints should show no signs of leakage.

## GENERAL INSTRUCTIONS FOR ORDERING PARTS

- Give serial number of pump or bearing unit.
- Give size and model of pump.
- Give part numbers.
- Give the diameter of Runners whether special or standard.
- Special Runners and other parts should be clearly specified.

## MODEL K ASSEMBLY PROCEDURES

### To Assemble Intake Chamber On Frame Base (6SB)

1. Position Intake Chamber on Frame Base mounting pads in alignment with mounting holes.
2. Install Intake Chamber Cap Screws (6E) in tapped holes in Frame Base.
3. Install Case Stud Bolts (39) in tapped holes in front face of Intake Chamber.

### To Assemble Intake Chamber (6SA)

1. Install two Follower Plate Pins (3) in front face of Intake Chamber.
2. Install Frame Packing Ring (42) in groove on front face of Intake Chamber.
3. Install Blind Intake Flange (36) on Intake Chamber.
4. Install Intake Spool (34) on Intake Chamber (Do this only on 1" through 2½" discharge pumps only).
5. Install Gland Stud Bolts (40) in tapped holes in rear face of Intake Chamber.

6. Install Draw Bolt (11), inner Draw Bolt Nut (11A) and Draw Bolt Washer (11B) on Intake Chamber.

### To Assemble Bearing Unit (13)

1. Heat Thrust Bearing (14) and Radial Bearing (32) to temperature of 175° – 200°F using bearing induction heater.
2. Install Thrust Bearing on Shaft (15) against front bearing shoulder.
3. Install Thrust Bearing Lockwasher (15C) on Shaft.
4. Install Thrust Bearing Locknut (15A) on Shaft.
5. Install Radial Bearing, Radial Bearing Lockwasher (15D) and Radial Bearing Locknut (15B) on rear of Shaft in the same manner as Thrust Bearing.
6. Carefully inset Shaft and Bearing into Long Cylinder (16). This can most easily be done by standing Long Cylinder on end.
7. Install Front Bearing Cap Oil Seal (55B) in Front Bearing Cap (55).
8. Install Front Bearing Cap on Long Cylinder using Front Bearing Cap Machine Screw (55A).
9. Install End Cap Oil Seal (32A) in End Cap (23).
10. Install End Cap on Long Cylinder using End Cap Capscrews (23B).
11. Install Short Cylinder (22) on Long Cylinder using Long Cylinder Capscrews (16D)

### To Assemble Check Valve Assembly (27)

1. Install Check Valve Spring (27D) in pocket of Check Valve Spider (27A).
2. Install Check Valve Packing Diaphragm Plate (27P) against Check Valve Spring and compress until Packing Diaphragm Plate is seated on Check Valve Spider (27A).
3. Install Check Valve Weight (27B) in slot and secure with Check Valve Cotter Pin (27E) and Check Valve Cotter Pin Washer (27T). Do the same with the other weight.



4. Install Check Valve Setscrew (27H) in Check Valve Sleeve (27J) and Check Valve Sleeve O-Ring (27S) in groove of Check Valve Sleeve.
5. Attach Check Valve Spider Assembly to Check Valve Sleeve (27J) using Check Valve Spider Machine Screws (27K).
6. Slide Check Valve Packing Diaphragm (27F) on barrel of Check Valve Sleeve and seat in pocket of Check Valve Packing Diaphragm Plate.
7. Slide Check Valve Assembly on Shaft until seated on Shift shoulder.
8. Align and tighten Check Valve Setscrew in notch on Shaft.
9. Install Short Cylinder Head (21) using Short Cylinder Head Machine Screw (21A). Check Valve Spring should be compressed.

### **To Assemble Bearing Unit Into Intake Chamber**

1. Push Gland Ring (7) over Short Cylinder with large flange facing toward Long Cylinder.
2. Install Bearing Unit in rear bore of Intake Chamber. Align Draw Bolt (11) with draw bolt lug on Long Cylinder. Front face of Short Cylinder Head should be flush with the inside face of the Intake Chamber.
3. Install Check Valve Setscrew (27H) in Check Valve Sleeve (27J) and Check Valve Sleeve O-Ring (27S) in groove of Check Valve Sleeve.
4. Install Pedestal Cap (28) on Frame Base with Pedestal Cap Capscrews (28E). Tighten only finger tight at this time.
5. Install 2 layers of Gland Packing Ring (41) in rear bore of Intake Chamber. Displace joints in rings 90° from each other to avoid leaking.
6. Bolt Gland Ring onto Gland Stud Bolts (40) using Gland Stud Bolt Nuts (40A). Nuts should only be hand tighten at this time.
7. Install Short Cylinder Cover (22C).

### **To Assemble wetted parts**

1. Install Die Ring (26) over hub of Short Cylinder Head using Die Ring Machine Screws (26A).
2. Install Frame Protecting Ring (6X) in front bore of Intake Chamber.

#### **Note: Install expeller for 2-piece runner only.**

3. Install Follower Plate (3) on two Follower Plate Pins (3E). Insure that Follower Plate Gasket (3A) is cemented in groove.
4. Install Runner (25) on Shaft. Insure that Runner Gasket (25A) is seated in groove at expeller and on Runner Bore.
5. Install Runner Bolt (29) on Shaft. Pull Runner forward to engage Runner Bolt in slot. Tighten down Runner. Runner should turn freely with no metallic scrapping.
6. Install Case (1) on Intake Chamber over Case Stud Bolts (39) using Case Stud Bolt Washers (39B) and Case Stud Bolt Nuts (38A).
7. To set Runner clearance, loosen outer Draw Bolt Nut and turn inner Draw Bolt Nut clockwise until Runner drags on Follower Plate. Loosen inner Draw Bolt Nut 1/4 turn and tighten outer Draw Bolt Nut.
8. Tighten Gland Stud Bolt Nuts.
9. Tighten Pedestal Cap Capscrews.

### **To Assemble Crane Assembly (37) (3K through 8K Pumps Only)**

1. Install Crane Pin (37A) in reamed hole in top left side of Intake Chamber
2. Slide Primary Crane Arm (37A) over Crane Pin.
3. Insert Crane Hinge Pin Ball (37E) in pocket in lower half of yoke in Primary Crane Arm.
4. Insert large end of secondary Crane Arm (37F) in yoke end of Primary Crane Arm.
5. Insert Crane Hinge Pin (37D) into aligned bore.
6. Install secondary Crane Arm Pin (37G).



7. Install Crane Hook (37H) through crane hook hole in case.
8. Inert Crane Hook in hole of secondary Crane Arm.
9. Install Crane Hook Washer (37K) and 2 Nuts (37J) on Crane Hook.

### To Assemble Discharge Keeper Assembly

1. Install Yoke Setscrew (33R) in Keeper Yoke (33A).
2. Install Yoke Setscrew Jam Nut (33S) on setscrew. Align 2 sides of square head parallel to axis of Keeper Yoke bore.
3. Thread Keeper Bolt (33B) into Keeper Pin (33A) 1/16" below surface of Pin.
4. Install assembled Keeper Pin and Bolt in Keeper Yoke.
  - a. Lubricate Keeper Pin.
  - b. Align keyway in Keeper Pin with square head on Keeper Yoke Setscrew.
  - c. Slide Keeper Pin into bore of Keeper Yoke.
  - d. Install Keeper Bolt Washer (33L) and Keeper Bolt Nut (33K) on Keeper Bolt. Draw nut up snugly.
  - e. Install Keeper Bolt Nut Pin (33M).
1. Install Discharge Keeper Sleeve (33C) (1K through 5K Pumps) or Discharge Keeper Slip Joint Assembly (33CA) (6K and 8K Pumps).
2. Install discharge Keeper Sleeve Bolt (33D) and Nut (33E).
3. On 3K and above, bolt Keeper Sleeve to discharge flange on Case. 1K through 2½K, tighten down Keeper Sleeve by tightening Keeper Bolt.
4. Note: For 6K and 8K Pumps, Draw Bolt type Discharge Keeper (33CA) is also available but does not use Yoke.

5. Note: Do not over tighten Case Discharge Flange Bolts (1B). The Case Gasket (1A) seal will be destroyed.

### KBA PUMP ASSEMBLY PROCEDURE

Note: Before assembly, coat all mating surfaces with an anti-rust, anti-galling compound.

#### Expeller Unit Assembly

1. Install assembly of Front Bearing Cap (55) and Front Bearing Cap Oil Seal (55B) on Long Cylinder (16) (with Shaft and Bearings in place) over Front Bearing Cap Indexing Pin (55C) and secure with the Front Bearing Cap Screws (55A). Note: The mating surfaces between the Front Bearing Cap and Long Cylinder should be coated with a gasket sealer before assembly.
2. Install Check Valve Sleeve O-ring (27S) in Check Valve Sleeve (27J).
3. Slide Check Valve Sleeve (27J) along Shaft (15) until Sleeve is shouldered on corresponding shaft shoulder and align one Check Valve Sleeve Socket Setscrew with notch on Shaft. Tighten (2) Check Valve Sleeve Socket Setscrews (27H) with standard hex socket key.
4. Position Short Cylinder (22) on Long Cylinder (16) and secure with (5) Long Cylinder Capscrews (16D).
5. Place Check Valve Gasket (27W) inside Short Cylinder (22) against the shoulder.
6. Slide Check Valve Diaphragm (27U) into Short Cylinder (22) against Check Valve Gasket (27W) with flat side of Check Valve Diaphragm (27U) away from Check Valve Gasket (27W).
7. Slide Expeller Plate Gasket (68B) No. 1 onto Check Valve Sleeve (27J) against Sleeve shoulder.
8. Push first Expeller Plate (68) onto Check Valve Sleeve (27J) against Expeller Plate Gasket (68B) No. 1 with pumping blades adjacent to Check Valve Diaphragm (27U).



9. Install first Expeller Ring Spacer (66) into Short Cylinder (2) against Check Valve Diaphragm (27U) and covering Expeller Plate (68). The hub of the Expeller Plate should extend slightly beyond the exposed face of the Expeller Ring Spacer.
10. Slide Expeller Plate Gasket (68B) No. 2 onto Check Valve Sleeve (27J) and against exposed hub face of first Expeller Plate (68).
11. Install second Expeller Plate (68) and second Expeller Ring spacer (66) in position with same orientations as first parts.
12. Place Expeller Plate Gasket (68B) No. 3 on Check Valve Sleeve (27) against the exposed hub face of the second Expeller Plate (68).
13. With threads of Check Valve Sleeve (27J) and Check Valve Sleeve Nut (27V) amply coated with anti-galling compound, install Check Valve Sleeve Nut (27J) and tighten snugly against Expeller Plate Gasket (68B) No. 3 with strap wrench.
14. With (4) Die Ring Studs (26B) installed in Die Ring (26), with threads bottomed in Die Ring, coat (4) Die Ring Studs with grease and place Die Ring Gasket (26K) on each stud and metal face of Die Ring.
15. Push Die Ring Stud assembly into (4) holes in Short Cylinder (22) and over second Expeller Ring Spacer (66). Mount Die Ring Stud Nuts (26D) on Die Ring Stud ends protruding into respective Short Cylinder openings. Tightening the Die Ring Stud Nuts firmly on the Die Ring Studs clamps all internal parts into position.

All parts should now be in their proper positions and relationships and the Shaft should turn easily by hand with no observable dragging of parts within the assembly.

### Pump Assembly

1. Bolt the Intake Chamber (6SA) firmly to the pump base. Install standard Case Stud Bolts (39), Discharge Keeper Assembly (33) and Discharge Keeper Pin Setscrew (33T).
2. Install the Gland Ring Packing (41) in the groove of the Intake Chamber and slide the Gland Ring (7) over the studs. Finger tighten nuts to retain in position.

3. Slide the modified KBA bearing unit to the Intake Chamber and position as with a standard pump. Attach Pedestal Cap (28) in normal manner.
4. Install Runner (25), Follower Plate (3) and Case (1) in normal manner, and adjust seals for proper operation. Snug up Gland Ring Nuts for leak-proof operation.

### Disassembly

Disassembly is accomplished primarily by reversal of this procedure. It must be emphasized that disassembly after unit has been in operation is accomplished more easily if ample coating of parts with anti-galling compound is done at original and subsequent assembly of unit.

### Recommended Spare Parts List (KBA Components)

<u>Part #</u>	<u>Part Name</u>	<u>Qty.</u>
26K	Die Ring Gasket	1
26	Die Ring – Rubber Covered	1
27S	Check Valve Sleeve O-ring	1
27U	Check Valve Diaphragm	1
27W	Check Valve Gasket	1
66	Expeller Ring Spacer (Rubber Covered)	2
68	Expeller Plate (Rubber Covered)	2
68B	Expeller Plate Gasket	3

### KBA EXPELLER AND CHECK VALVE UNITS

#### Function and Operation

This unit is, in general, similar in function to the previous KB unit in that it is capable of holding more intake head than the conventional K pump system which has only the single stage bell expeller.

Beyond the above similarities, the KBA units have different design concepts and capabilities as follows:

Parts exposed to slurry are covered with rubber to a depth of approximately twice that of a previous unit.

There is no key alignment requirement.

The Check Valve Sleeve incorporates a slinger area, at its outside diameter, which throws off any slurry which may be present and prevents bearing contamination.



The Check Valve System is based on a molded Diaphragm which operates with slurry pressure at shutdown. When pump is running, the Diaphragm is at rest with atmospheric pressure on both sides and has no running contact with any pump part. At shutdown, intake and, or, discharge head pressure pushes the Diaphragm against the seal area of the Check Valve Sleeve and a seal is accomplished.

Flushing capability is provided to the rear Expeller stage. This allows periodic flushing by applying plant water pressure to 1/4" plumbing, which is provided with each unit. Passages for flushing water are provided through a hole in the Short Cylinder and through slots and grooves in the Check Valve Diaphragm Assembly.

Note: The flushing system is also used to purge air from the remote Expeller areas at start-up. When slurry is first introduced to the pump it is necessary to open the flushing pumping petcock until slurry emerges following the blowing off of air from the pump and Expeller cavities.

The purging of air from the unit is necessary in that air which is trapped will mix with slurry and reduce the actual specific gravity of the slurry in the Expeller cavities and thus reduces the system's head holding capacity, causing it to leak while running.

It is highly recommended that, prior to reassembling the KBA unit, all mating surfaces be coated with an effective anti-rust or anti-galling compound to insure ease of disassembly at some future date.

After removal from Long Cylinder, total disassembly of the KBA unit is accomplished by backing off of the two Check Valve Sleeve Setscrews, removal of the Die Ring Stud Nuts (26D) and the removal of the Check Valve Sleeve Nut (right hand thread).

## INSTALLATION PROCEDURE FOR KBA PACKAGE EXPELLER UNIT

1. Slide unit on Shaft until Short Cylinder face engages Long Cylinder face and install Long Cylinder Capscrew (16D).
2. Push Expeller and Check Valve Sleeve Assembly toward Long Cylinder in order to position Check Valve Sleeve shoulder against pump Shaft shoulder. This establishes correct clearance relationships.
3. With operation 2 in effect, tighten the Check Valve Sleeve Socket Setscrews (27H) in Check Valve Sleeve (slinger portion) finger tight with standard socket key. One setscrew must be located at flat on pump Shaft.
4. Proceed to tighten setscrews alternately in 2 or 3 steps. This will prevent the possibility of forcing the slinger out of concentricity with the Short Cylinder.
5. Install remaining pump parts as usual.
6. Check unit for freedom of rotation.
7. Reverse procedure (1-4) for disassembly.

### These Parts Can Be Purchased As An Assembled Package Unit

22	27H	27W
26	27J	66
26B	27S	68
26D	27U	68B
26K	27V	



# MODEL K PARTS LIST AND SECTIONAL VIEW

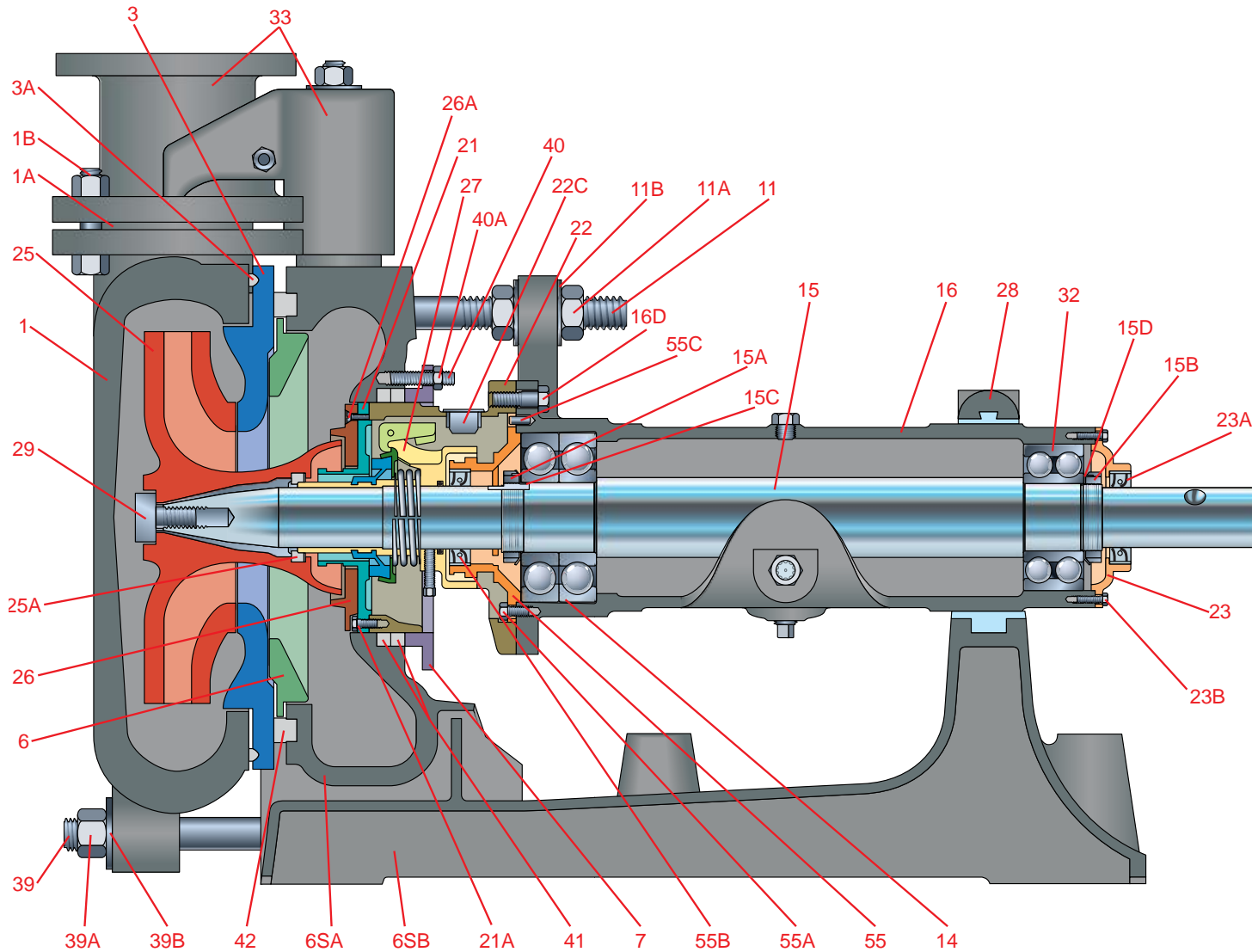

Part #	Part Name
1	Case
1A	Case Gasket
1B	Case Discharge Flange Bolt
3	Follower Plate
3A	Follower Plate Gasket Assembly
6E	Intake Chamber Capscrew (N.I.)
6SA	Intake Chamber
6SB	Frame Base
6X	Frame Protecting Ring
7	Gland Ring
11	Draw Bolt
11A	Draw Bolt Nut
11B	Draw Bolt Washer
14	Thrust Bearing
15	Shaft
15A	Shaft Thrust Bearing Locknut
15B	Shaft Radial Bearing Locknut
15C	Shaft Thrust Bearing Lockwasher
15D	Shaft Radial Bearing Lockwasher
16	Long Cylinder
16D	Long Cylinder Capscrew
21	Short Cylinder Head
21A	Short Cylinder Head Machines Screw
22	Short Cylinder
22C	Short Cylinder Cover
23	End Cap
23A	End Cap Oil Seal
23B	End Capscrew
25	Runner
25A	Runner Gasket
26	Die Ring
26A	Die Ring Machine Screw
27	Check Valve Assembly
28	Pedestal Cap
28E	Pedestal Cap Capscrew (N.I.)
29	Runner Bolt
32	Radial Bearing
33	Discharge Keeper Assembly
37	Crane Assembly (N.I.)
39	Case Stud Bolt
39A	Case Stud Bolt Nut
39B	Case Stud Bolt Washer
40	Gland Stud Bolt
40A	Gland Stud Bolt Nut
41	Gland Packing Ring
42	Frame Packing Ring
55	Front Bearing Cap
55A	Front Bearing Cap Machine Screw
55B	Front Bearing Cap Oil Seal
55C	Front Bearing Cap Indexing Pin

Note: N.I. – Not Illustrated



## QUICK CHANGE FEATURES



The four wear parts – Case, Runner, Die Ring and Follower Plate – can be changed within a few minutes without disturbing the intake or discharge piping. This quick change is made possible by the rear Intake, the Discharge Keeper and the manner in which the Runner is attached to the Shaft.

## MODEL K TRASH PUMP

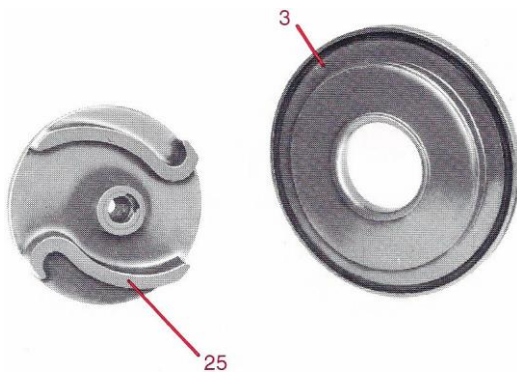

<u>Part #</u>	<u>Part Name</u>
3	Follower Plate
25	Runner

## METAL PUMPING PARTS – ONE PIECE RUNNER

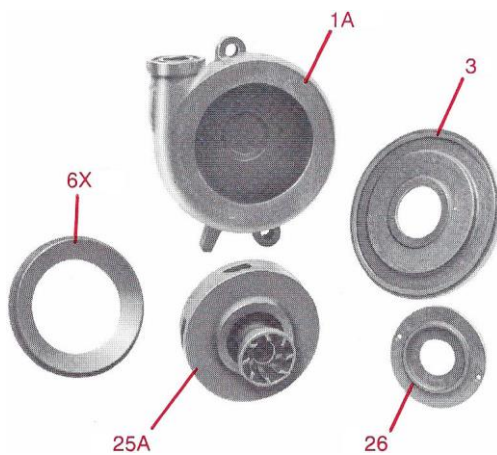

<u>Part #</u>	<u>Part Name</u>
1	Case
1A	Case Gasket
3	Follower Plate
6X	Frame Protecting Ring
25	Runner
25A	Runner Gasket
26	Die Ring



## METAL PUMPING PARTS – TWO PIECE RUNNER

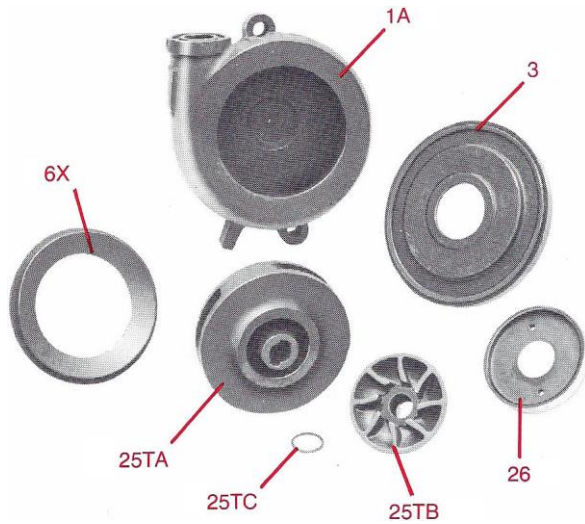

### Part # Part Name

1	Case
1A	Case Gasket
3	Follower Plate
6X	Frame Protecting Ring
25TA	Runner, Bayonet Type
25TB	Expeller
25TC	Runner, Expeller O-ring
26	Die Ring

## RUBBER LINED CASE, REPLACEABLE LINER TYPE

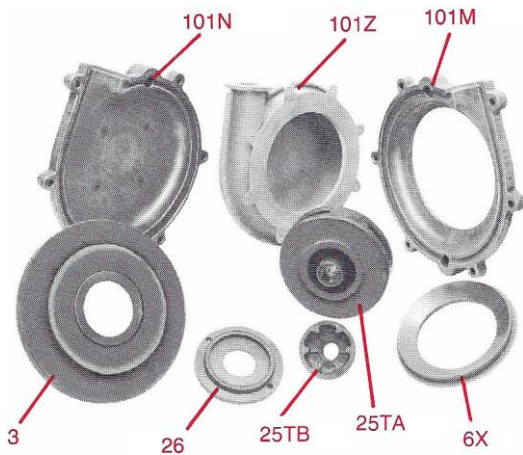

### Part # Part Name

3	Follower Plate
6X	Frame Protecting Ring
25TA	Runner
25TB	Expeller, Bayonet Type
26	Die Ring
101N	Case Shell, Closed Half
101M	Case Shell, Open Half
101Z	One Piece Liner

## MANUALLY RUBBER LINED CASE



### Part # Part Name

1	Manually Rubber Lined Case (No Case Gasket required)
---	---------------------------------------------------------



## CHECK VALVE ASSEMBLY (27)

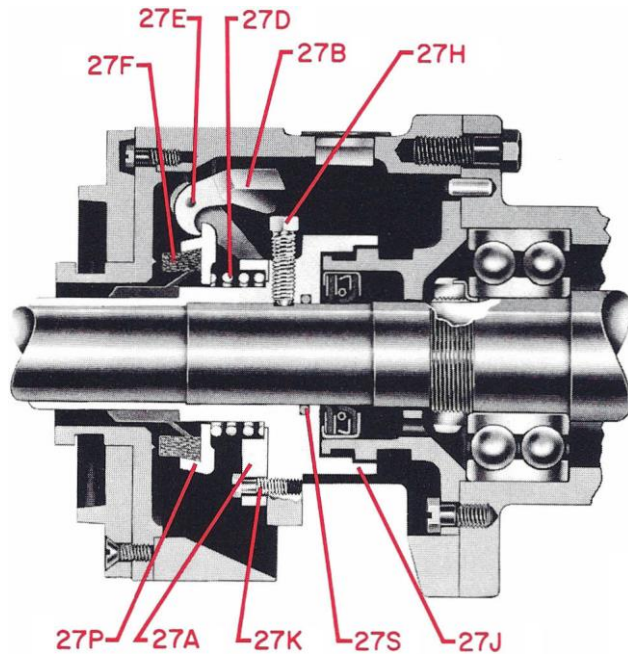

### Part # Part Name

27	Check Valve Assembly
27A	Check Valve Spider
27B	Check Valve Weight
27D	Check Valve Spring
27E	Check Valve Cotter Pin
27F	Check Valve Packing Diaphragm
27H	Check Valve Sleeve Setscrew
27J	Check Valve Sleeve
27K	Check Valve Spider Machine Screw
27P	Check Valve Packing Diaphragm Plate
27S	Check Valve Sleeve O-Ring
27T	Check Valve Cotter Pin Washer (N.I.)

**Note: N.I. – Not Illustrated**

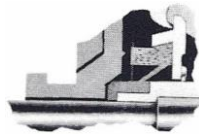

**VARIATION OF CHECK VALVE  
FOR 1" – 2½" PUMPS**

## CRANE ASSEMBLY (37) USED ON 3K THROUGH 8K ONLY

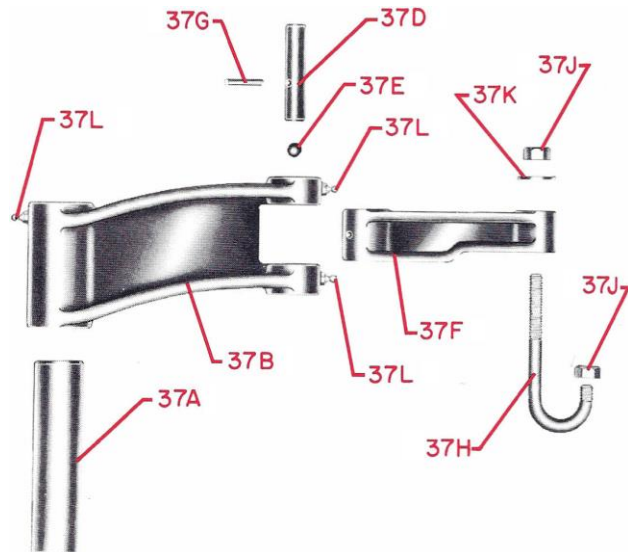

### Part # Part Name

37A	Crane Pin
37B	Primary Crane Arm
37C	Primary Crane Arm Rivet (N.I.)
37D	Crane Hinge Pin
37E	Crane Hinge Pin Ball
37F	Secondary Crane Arm
37G	Secondary Crane Arm Pin
37H	Crane Hook
37J	Crane Hook Nut
37K	Crane Hook Washer
37L	Crane Grease Fitting

**Note: N.I. – Not Illustrated**



## EXPELLER DEFLECTOR RING (62) – 8K ONLY

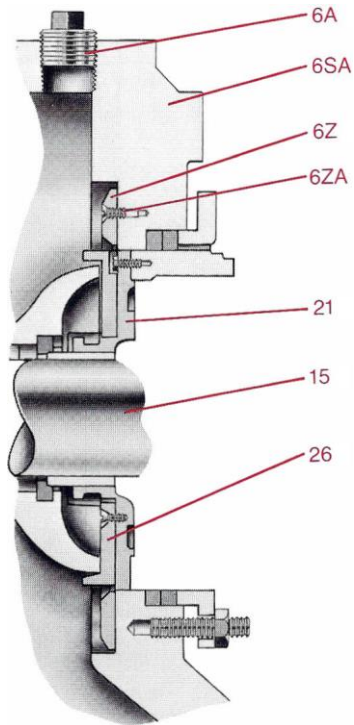

### Part # Part Name

6S	Intake Chamber Vent Plug
6SA	Intake Chamber
6Z	Expeller Deflector Ring
6ZA	Expeller Deflector Ring Screws
15	Shaft
21	Short Cylinder Head
26	Die Ring

## INTAKE SPOOL (1" THROUGH 2½" PUMPS ONLY) BLIND FLANGE ON ALL SIZES

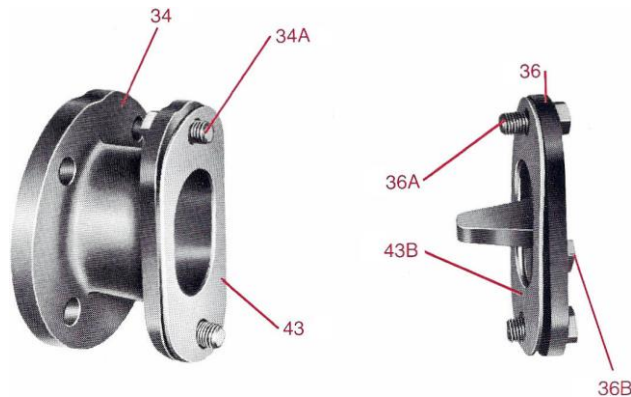

### Part # Part Name

34	Intake Spool
34A	Intake Spool Capscrew
36	Blind Intake Flange
36A	Blind Intake Flange Capscrew
36B	Blind Intake Flange Pipe Plug
43	Intake Spool Gasket
43B	Blind Intake Flange Gasket



## DISCHARGE KEEPER ASSEMBLY (33) FOR 1K THROUGH 5K ONLY

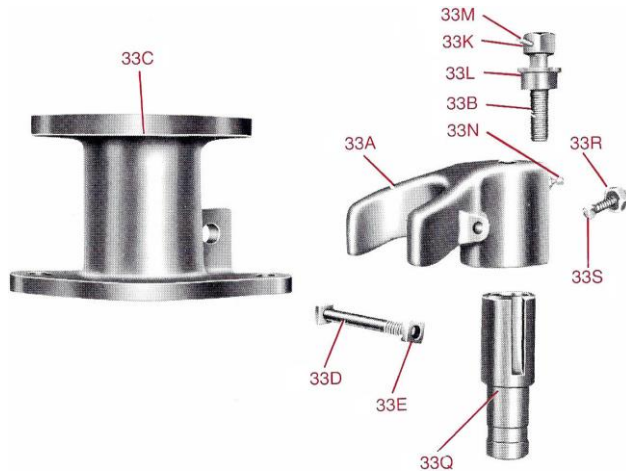

### Part # Part Name

33A	Discharge Keeper Yoke
33B	Discharge Keeper Bolt
33C	Discharge Keeper Sleeve
33D	Discharge Keeper Sleeve Bolt
33E	Discharge Keeper Sleeve Bolt Nut
33K	Discharge Keeper Bolt
33L	Discharge Keeper Bolt Washer
33M	Discharge Keeper Bolt Nut
33N	Discharge Keeper Grease Fitting
33Q	Discharge Keeper Pin
33R	Discharge Keeper Yoke Setscrew
33S	Discharge Keeper Yoke Setscrew Jam Nut
33T	Discharge Keeper Pin Setscrew (N.I.)
33U	Discharge Keeper Pin Setscrew Jam Nut (N.I.)

**Note:** N.I. – Not Illustrated

## DISCHARGE KEEPER SLIP JOINT ASSEMBLY (33CA) FOR 6K AND 8K ONLY (YOKE TYPE)



### Part # Part Name

33A	Discharge Keeper Yoke
33B	Discharge Keeper Bolt
33D	Discharge Keeper Sleeve Bolt
33E	Discharge Keeper Sleeve Bolt Nut
33K	Discharge Keeper Bolt Nut
33L	Discharge Keeper Bolt Washer
33M	Discharge Keeper Bolt Nut Pin
33N	Discharge Keeper Grease Fitting
33Q	Discharge Keeper Pin
33R	Discharge Keeper Yoke Setscrew
33S	Discharge Keeper Yoke Setscrew Jam Nut
33CA	Discharge Keeper Sleeve Slip Joint Assy
33CB	Slip Joint Gland Ring
33CC	Gland Ring Bolt
33CD	Gland Ring Bolt Nut
33CE	Gland Ring Bolt Washer
33CF	Slip Joint Gland Packing Ring
33CG	Packing Sleeve
33CH	Packing Sleeve Grease Fitting
33CJ	Discharge Sleeve

Yoke and Discharge Keeper Slip Joint Assembly may be ordered separately



## DISCHARGE KEEPER SLIP JOINT ASSEMBLY (33CA) FOR 6K AND 8K ONLY (DRAWBOLT TYPE)

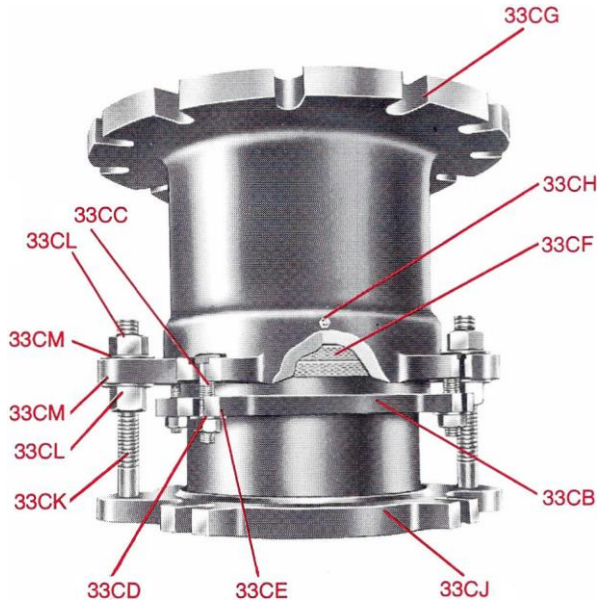

<u>Part #</u>	<u>Part Name</u>
33CB	Slip Joint Gland Ring
33CC	Gland Ring Bolt
33CD	Gland Ring Bolt Nut
33CE	Gland Ring Bolt Washer
33CF	Slip Joint Gland Packing Ring
33CG	Packing Sleeve
33CH	Packing Sleeve Grease Fitting
33CJ	Discharge Sleeve
33CK	Slip Joint Draw Bolt
33CL	Slip Joint Draw Bolt Nut
33CM	Slip Joint Draw Bolt Washer

## BEARING UNIT ASSEMBLY (13)

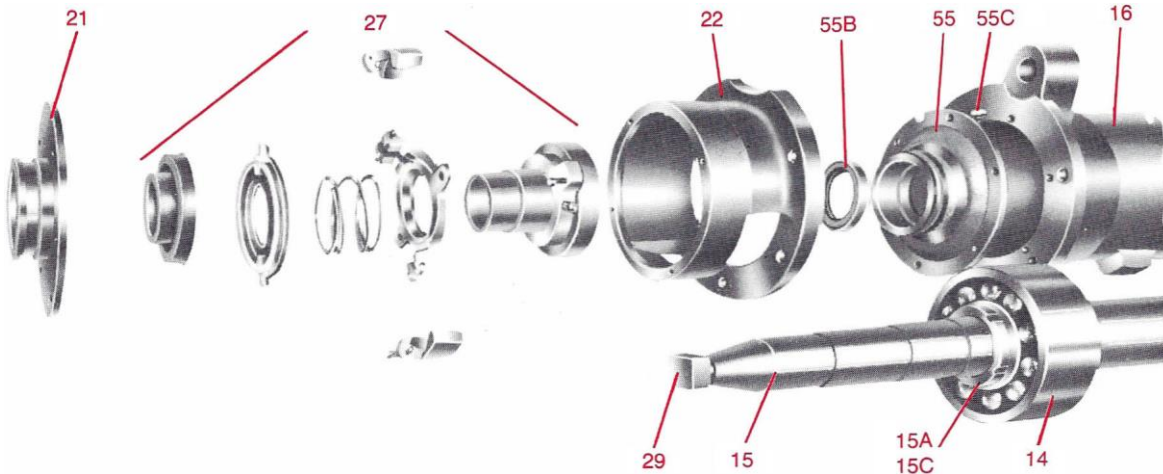

<u>Part #</u>	<u>Part Name</u>
14	Thrust Bearing
15	Shaft
15A	Shaft Thrust Bearing Nut
15C	Shaft Thrust Bearing Lockwasher
16	Long Cylinder
21	Short Cylinder Head
22	Short Cylinder
27	Check Valve Assembly (See Assembly)
29	Runner Bolt
55	Front Bearing Cap
55B	Front Bearing Cap Oil Seal
55C	Front Bearing Cap Indexing Pin

<u>Part #</u>	<u>Part Name</u>
15B	Radial Bearing Lock Nut (N.I.)
15D	Radial Bearing Lock Washer (N.I.)
16A	Long Cylinder Oil Fill Plug (N.I.)
16B	Long Cylinder Oil Drain Plug (N.I.)
16C	Long Cylinder Oil Sight Glass (N.I.)
16D	Long Cylinder Capscrew (N.I.)
21A	Short Cylinder Head Bolt (N.I.)
22C	Short Cylinder Cover (N.I.)
23	End Cap (N.I.)
23A	End Cap Oil Seal (N.I.)
23B	End Cap Capscrew (N.I.)
32	Radial Bearing (N.I.)
55A	Front Bearing Cap Bolt (N.I.)



**Note: N.I. – Not Illustrated**  
**MODEL KBA PUMP (SPECIAL EXPELLER PACKAGE) (64)**

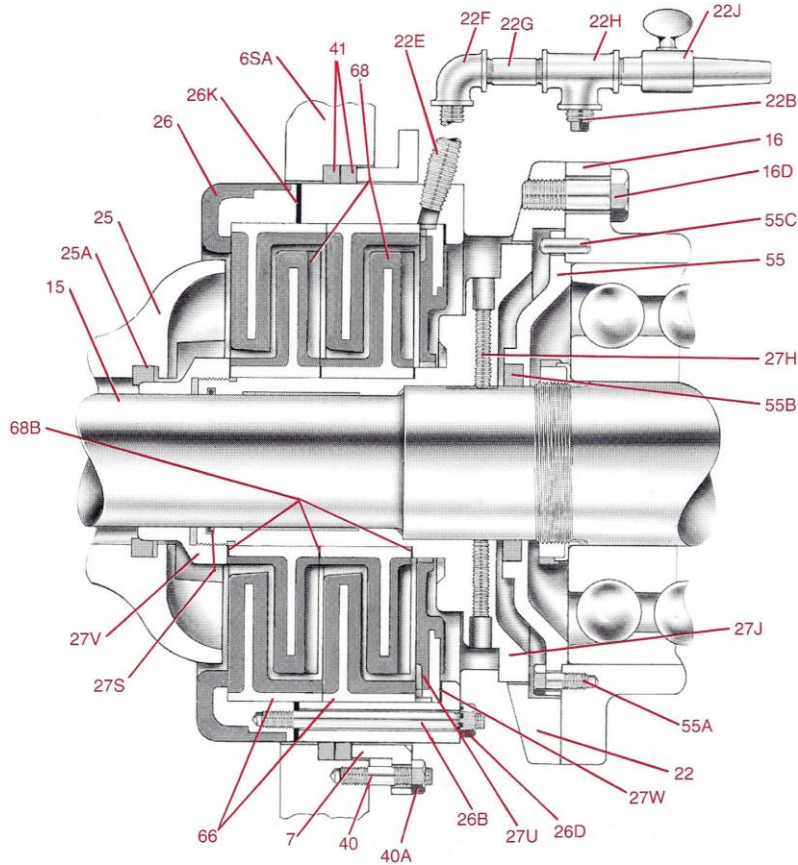

**MODEL KBA**

**Part # Part Name**

6SA	Intake Chamber
7	Gland Ring
15	Shaft
22	Short Cylinder
22B	Short Cylinder Flushing Plug
22E	Short Cylinder Flushing Close Nipple
22F	Short Cylinder Flushing 90° Elbow
22G	Short Cylinder Flushing Nipple
22H	Short Cylinder Flushing Tee
22J	Short Cylinder Flushing Petcock
26	Die Ring – Rubber Covered
26B	Die Ring Stud
26D	Die Ring Stud Slotted Angle Hex Nut
26K	Die Ring Gasket

**Part # Part Name**

27H	Check Valve Sleeve Socket Setscrew
27J	Check Valve Sleeve
27S	Check Valve Sleeve O-Ring
27U	Check Valve Diaphragm
27V	Check Valve Sleeve Nut
27W	Check Valve Gasket
40	Gland Stud Bolt
40A	Gland Stud Bolt Nut
41	Gland Packing Ring
55	Front Bearing Cap
55B	Front Bearing Cap Oil Seal
66	Expeller Ring Spacer – Rubber Covered
68	Expeller Plate – Rubber Covered
68B	Expeller Plate Gasket

**STANDARD ON “K” MODEL**

**Part # Part Name**

16	Long Cylinder
16D	Long Cylinder Capscrew
25	Runner

**Part # Part Name**

25A	Runner Gasket
55A	Front Bearing Cap Machine Screw
55C	Front Bearing Cap Indexing Pin



## MODEL KH PUMP (WETTED-END)

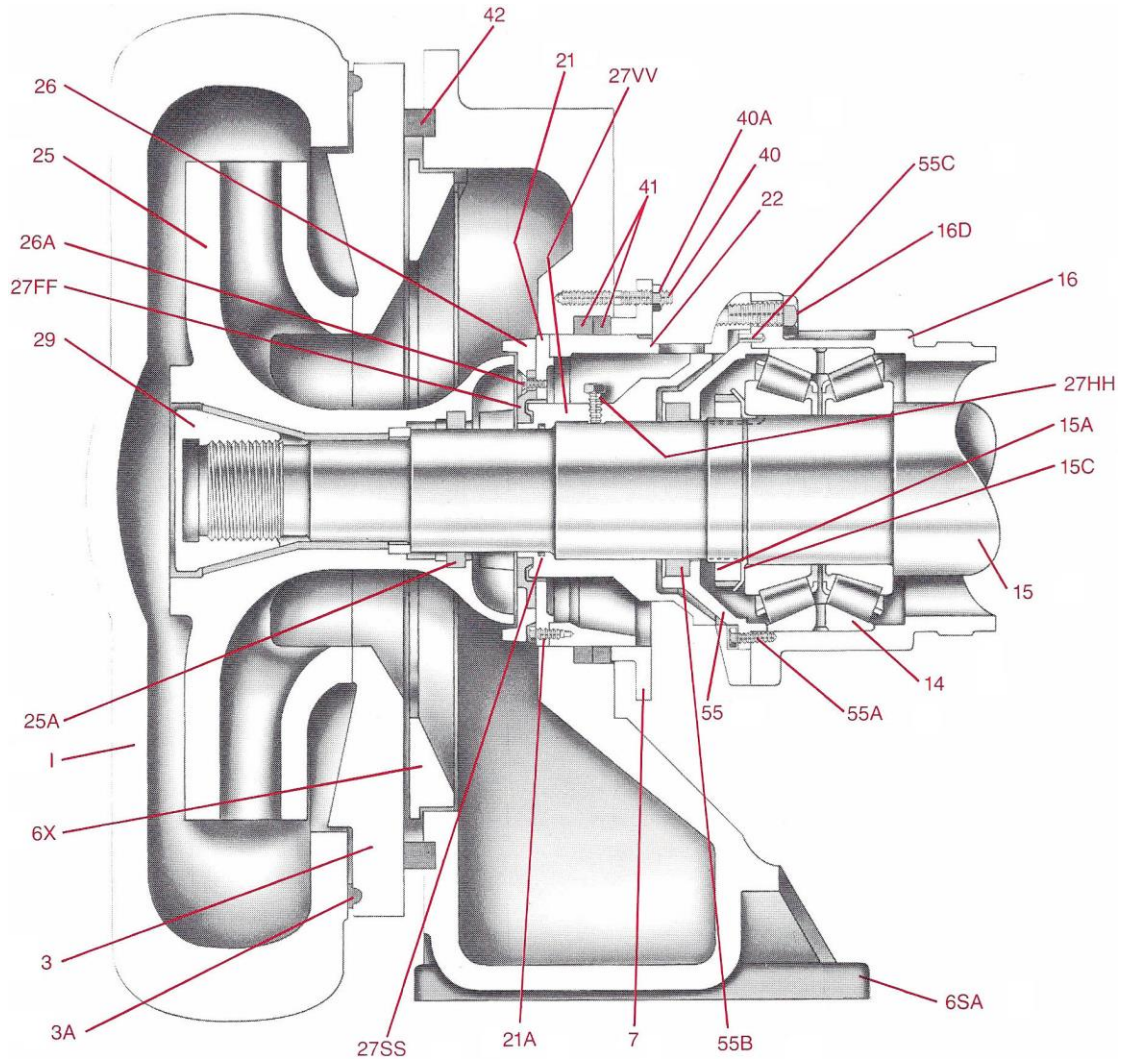

### Part # Part Name

1	Case
3	Follower Plate
3A	Follower Plate Gasket Assembly
6SA	Intake Chamber
6SB	Frame Base (N.I.)
6X	Frame Protecting Ring
7	Gland Ring
14	Thrust Bearing
15	Shaft
15A	Shaft Thrust Bearing Nut
15C	Shaft Thrust Bearing Lockwasher
16	Long Cylinder
16D	Long Cylinder Capscrew
21	Short Cylinder Head
21A	Short Cylinder Head Machine Screw
22	Short Cylinder
25	Runner

### Part # Part Name

25A	Runner Gasket
26	Die Ring
26A	Die Ring Machine Screw
27FF	Check Valve Diaphragm
27HH	Check Valve Hub Setscrew
27SS	Check Valve Hub O-ring
27VV	Check Valve Hub
29	Runner Bolt
40	Gland Stud Bolt
40A	Gland Stud Bolt Nut
41	Gland Packing Ring
42	Frame Packing Ring
55	Front Bearing Cap
55A	Front Bearing Cap Machine Screw
55B	Front Bearing Cap Oil Seal
55C	Front Bearing Cap Indexing Pin

**Note: N.I. – Not Illustrated**



## MODEL K CORROSION AND ABRASION RESISTANT PUMP (WETTED-END)

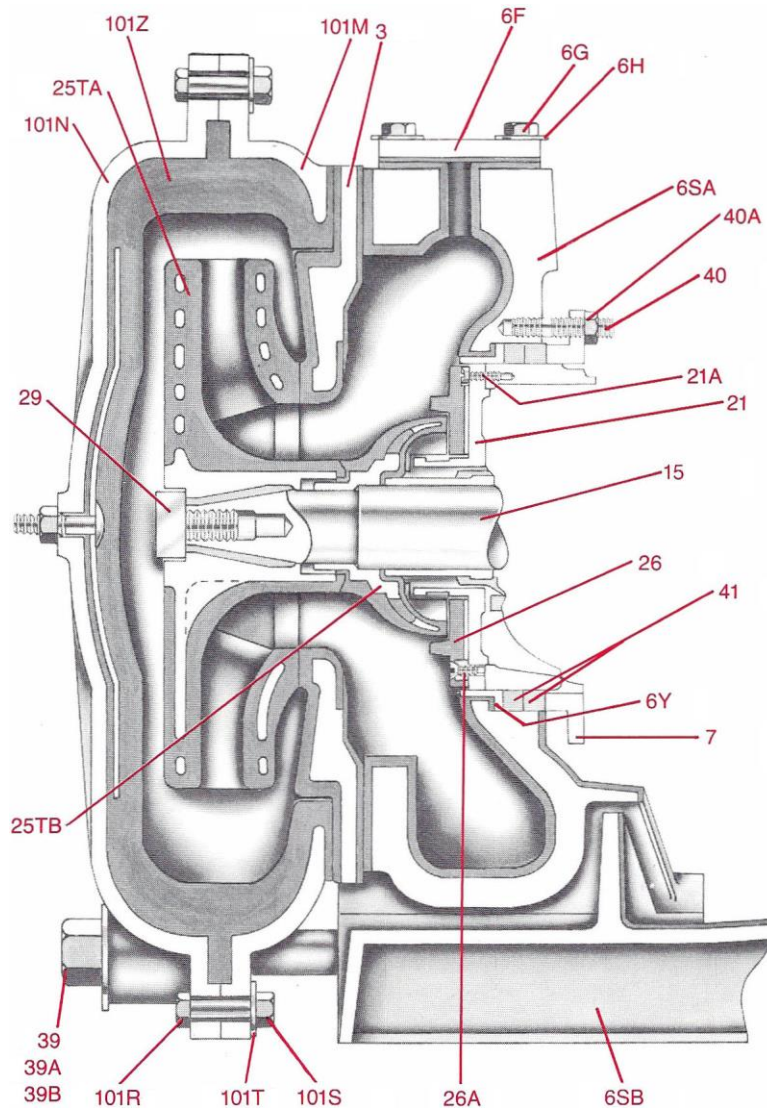

**Part # Part Name**

3	Rubber Covered Follower Plate
6F	Rubber Covered Intake Chamber Vent Cover
6G	Intake Chamber Vent Cover Capscrew
6H	Intake Chamber Vent Cover Washer
6SA	Rubber Lined Intake Chamber
6SB	Rubber Covered Frame Base
6Y	Short Cylinder Protecting Ring
7	Gland Ring
15	Shaft
21	Short Cylinder Head
21A	Short Cylinder Head Machine Screw
25TA	Rubber Runner
25TB	Rubber Expeller
26	Rubber Covered Die Ring

**Part # Part Name**

26A	Die Ring Machine Screw
29	Runner Bolt
39	Case Stud Bolt
39A	Case Stud Bolt Nut
39B	Case Stud Bolt Washer
40	Gland Stud Bolt
40A	Gland Stud Bolt Nut
41	Gland Packing Ring
101M	Case Shell-Open Half
101N	Case Shell-Closed Half
101R	Case Shell Bolt
101S	Case Shell Bolt Nut
101T	Case Shell Bolt Washer
101Z	One Piece – Rubber Lined Case

### GUARDS, FIXTURES, AND COUPLINGS



## DIRECT DRIVEN PUMP COUPLING GUARD

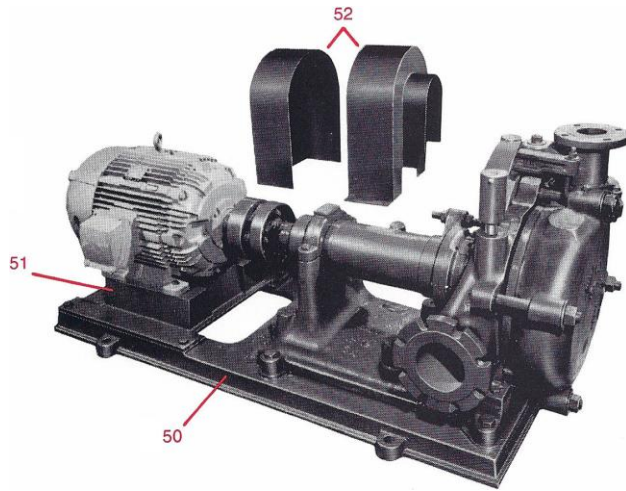

### Part # Part Name

50	Subbase
51	Motor Pedestal
52	Coupling Guard
52A	Coupling Guard Capscrew

## DIRECT DRIVEN PUMP COUPLING (44)

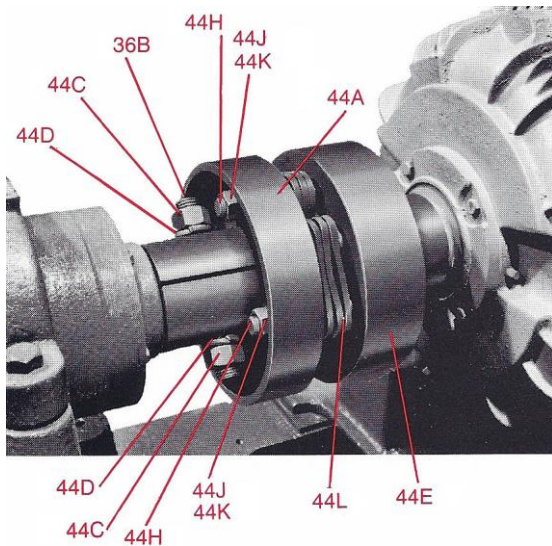

### Part # Part Name

44A	Flexible Coupling Pump Half
44B	Flexible Coupling Bolt
44C	Flexible Coupling Bolt Nut
44D	Flexible Coupling Bolt Lockwasher
44E	Flexible Coupling Motor Half
44H	Flexible Coupling Pin
44J	Flexible Coupling Pin Nut
44K	Flexible Coupling Pin Lockwasher
44L	Flexible Coupling Link



## OVERHEAD FIXTURE ASSEMBLY (60) AND DRIVE GUARD ASSEMBLY (60AA)

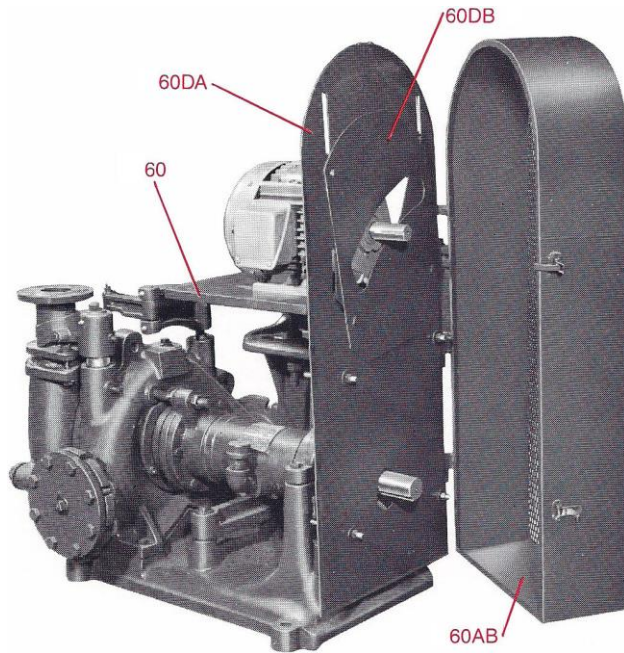

### Part # Part Name

60	Overhead Fixture Assembly
60A	OH Fixture Frame (N.I.)
60B	OH Fixture Motor Platform (N.I.)
60C	OH Fixture Fulcrum Bar (N.I.)
60F	OH Fixture Eyebolt Pin (N.I.)
60H	OH Fixture Eyebolt (N.I.)
60AA	Overhead V-belt Guard Assembly
60AB	OHV Guard Front Cover
60DA	OHV Guard Rear Plate
60DB	OHV Cover Plate

**Note: N.I. – Not Illustrated**



## TROUBLE SHOOTING GUIDE

PROBLEM	POSSIBLE CAUSE	SOLUTION
A. Low Capacity	1. Pump Intake not flooded.	1. Pump must have positive intake head. Does not have suction characteristics.
	2. Runner / Follower Plate slippage seal clearance is too great, which causes recirculation resulting in loss of discharge head and capacity. Incorrect slippage seal clearance is indicated when horsepower does not reduce at lower capacities.	1. Adjust slippage seal clearance. Metal wetted parts can be adjusted while pump is running. For rubber wetted parts, pump must be stopped.
	3. Wetted parts worn excessively.	1. Check pump Runner and Follower Plate Seals for excessive wear. Replace parts if 1/16" to 1/8" slippage seal clearance cannot be achieved or hole is worn through Runner shrouds or body of Follower Plate.
	4. Pump speed too low.	1. Check V-Belts for slippage due to improper belt tension. Adjust to proper tension.
	5. Improper pump Runner diameter.	1. Check pump Runner specification to insure Runner is proper size as recommended by Wilfley for the pumping conditions.
	6. Clogged intake or discharge piping	1. Flush piping.
	7. Increase in viscosity of slurry resulting in increased friction loss in pump and piping.	1. Reduce viscosity to original pumping conditions. 2. Contact Wilfley Engineering Department for recommendations of larger pump size to handle froth / foam conditions.
	8. Nature of pumped solution to froth or foam.	1. Add defoamers. 2. Contact Wilfley Engineering Department for recommendations of larger pump size to handle froth / foam conditions.
B. Pump leaks while running.	1. Intake head on pump is too great for expeller (pump) speed.	1. Throttle intake to pump to originally designed intake head conditions. 2. Contact Wilfley Engineering Department to recheck pump speed. With speed increase, Runner diameter may have to be changed to smaller diameter to maintain original pump capacity.
	2. Clearance between Die Ring and Expeller faces increases due to wear. Clearance should be 3/32" Maximum.	1. Replace worn pump Runner / Expeller or Die Ring or both.
	3. Worn Short Cylinder Head.	1. Replace Short Cylinder Head if hole is worn through face of part.
	4. Leakage through Short Cylinder Gland Ring Packing.	1. Tighten Gland Ring Nuts. 2. Check for worn Gland Packing Ring and wear on Short Cylinder seal face for Gland Packing Ring. Replace worn parts.
	5. Bent pump Shaft causing Runner / Expeller misalignment with Die Ring.	1. Replace pump Shaft.



PROBLEM	POSSIBLE CAUSE	SOLUTION
C. Pump leaks when shut down.	1. Check Valve Inoperative because of clogging with solids.	1. Disassemble Check Valve Assembly and clean thoroughly. 2. Install water flushing line in Short Cylinder into Check Valve area. Some applications require continuous water supply.
	2. Check Valve Packing Diaphragm may be torn or incorrectly installed.	1. Replace torn Check Valve Packing Diaphragm. 2. Insure that Check Valve Packing Diaphragm is properly seated in Check Valve Packing Diaphragm Plate.
	3. Excessive intake head on pump can overcome Check Valve Spring pressure causing leakage at shut down.	1. Reduce intake head to original design operating condition.
D. Pump vibration while running.	1. Pump Runner out of balance by wear.	1. Replace pump Runner.
	2. Loose Pedestal Cap Screws.	1. Tighten screws.
	3. Loose Gland Stud Bolt Nuts.	1. Tighten nuts.
	4. Rubbing contact between Runner and Follower Plate Slippage seals.	1. Adjust Draw Bolt to eliminate rubbing contact of seals.
	5. Out of balance conditions due to bent pump shaft.	1. Replace pump Shaft.
E. Excessive wear on wetted parts.	1. Pump speed too high resulting in increased fluid velocity.	1. Pump may be too small for application. Contact Wilfley Engineering Department for verification of operating conditions versus pump size.
	2. Intake head to pump may be too high resulting in increased fluid velocity.	1. Throttle intake to pump to original operating conditions.
	3. Type of material used in wetted parts unable to withstand the abrasion of the pumping application.	1. Consult Wilfley Engineering Department to select a more abrasion resistant material for the wetted parts.
F. Pump Surges	1. Pump may be overspeeded resulting in widely fluctuating intake head to cause surging.	1. Consult Wilfley Engineering Department for recommendations to reduce pump speed.
	2. Widely fluctuating feed flow into pump sump tank.	1. Stabilize feed flow into pump sump tank.
G. Air Binding	1. Frothing condition of pumped fluid.	1. Use defoamer. 2. Consult Wilfley Engineering Department. Larger pump may be required to handle increased volume due to froth condition.
	2. Air trapped in Intake Chamber.	1. Install standpipe vent in boss provided on top of Intake Chamber.
H. Bearing Failure	1. Contamination of bearings.	1. Check and replace Front Bearing Cap Oil Seal if defective. 2. Replace pump Shaft when oil seal journal is scored sufficiently to cause damage to oil seal lip.



PROBLEM	POSSIBLE CAUSE	SOLUTION
	2. Improper lubrication of bearings.	1. Use only bearing lubricants recommended by A.R. Wilfley and Sons, Inc. or bearing manufacturer. Use 300 second viscosity turbine oil or SAE/20 non-detergent motor oil. 2. Maintain proper oil level in Long Cylinder. Recommended oil level is 1/4" above inside surface of Oil Filler Elbow in Long Cylinder. Avoid excess use of lubricant.
	3. Excessive load on Radial (Rear) Bearing.	1. Check and adjust V-belts to proper tension on V-belt driven pumps. 2. Check alignment of Drive Coupling on Direct Driven pumps.
I. Runner Bolt Failure	1. Improper match of tapers on Shaft and Runner bore.	1. Insure Runner and Shaft taper fit tightly without perceptible "rocking." Shaft taper and taper in Runner bore must be free of raised "nicks."
	2. Runner bolt not torqued properly on Shaft.	1. Runner Bolt must draw Runner tight on Shaft taper during installation of Runner.
J. Runner Failure	1. Improper handling of brittle abrasion resistant parts.	1. Avoid careless handling of brittle pump parts during storage and pump assembly.
	2. Tramp material entering pump.	1. Install screening devices to eliminate tramp material from entering pump sump tank. Screen maintenance is important to detect and eliminate holes worn in the screen.
	3. Failure of babbitted taper in Runner bore.	1. Avoid "jogging" start and stop buttons on pump. This procedure induces high compressive stresses on babbitt. 2. Consult Wilfley Engineering Department for availability of higher hot strength babbitt when pumped solution temperatures exceed 150° F
K. Pump Case and Follower Plate failure due to fracture.	1. Uneven torquing of Case Stud Bolt Nuts.	1. Tighten opposite nuts alternately a small amount at a time until equal torquing is achieved.
	2. Pump Case improperly aligned with Follower Plate.	1. During installation of pump Case insure that sealing face of Case is parallel to sealing face of Follower Plate and Follower Plate Gasket before tightening Case Stud Bolt Nuts.