



Ball Valves (B12 Series)

Bulletin 4121-B12
May 2002

Introduction

Parker manually and pneumatically actuated two-way B12 Series Ball Valves provides quick 1/4 turn on-off control of fluids used in process and instrumentation applications.



Features

- Blow-out resistant stem
- Spring-loaded ball seats
- Bi-directional flow
- Stainless steel construction
- Micro-finished ball provides positive seal
- Handle indicates flow direction
- Color coded handles
- Low operating torques
- Optional pneumatic actuation
- 100% factory tested

Specifications

- Pressure Rating: 4000 psig (276 bar) CWP
- Temperature Rating: -65 °F to 350 °F (-54 °C to 177 °C)
- Orifice: 0.50" (12.7mm)
- Flow Data: $C_V = 9.09$; $x_T = 0.32$

Dimensions

Port Size	Basic Part No.	End Connections		Dimensions Inches (mm)	
		Port 1	Port 2	A	B
12A	B12L	3/4" A-LOK®		2.53	2.53
12Z		3/4" CPI™		(64.3)	(64.3)
12F		3/4" Female NPT		2.47	2.47
				(62.7)	(62.7)
16A		1" A-LOK®		2.90	2.90
16Z		1" CPI™		(73.7)	(73.7)
16F	1" Female NPT		2.69	2.69	
			(68.3)	(68.3)	

For CPI™ and A-LOK®, dimensions A and B are measured with nuts in the finger tight position

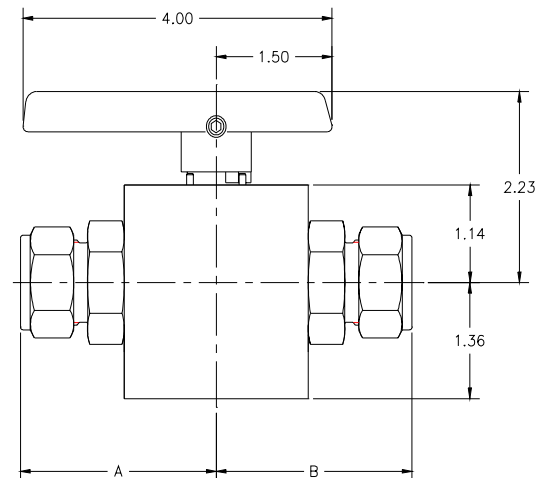

Materials of Construction

Item #	Part Description	Material
1	Body	ASTM A 479 Type 316
2	End Connector	ASTM A 479 Type 316
3	Ball	ASTM A 276 Type 316
4	Seat	PCTFE
5	Seat Retainer	ASTM A 276 Type 316
6	Connector O-Ring	Optional Elastomers
7	Stem O-Ring	Optional Elastomers
8	Back-up Ring (Stem)	PTFE
9	Stem Washer	PEEK
10	Stem	ASTM A 276 Type 316
11	Handle Pin	ASTM A 479 Type 316
12	Seat Spring	ASTM A 313 Type 631
13	Seat Retainer O-Ring	Optional Elastomers
14	Back-up Ring (Seat Retainer)	PTFE
15	Handle	Nylon 6/6
16	Handle Set Screw	316 Stainless Steel
17	Plug	316 Stainless Steel

Lubrication: Perfluorinated Polyether

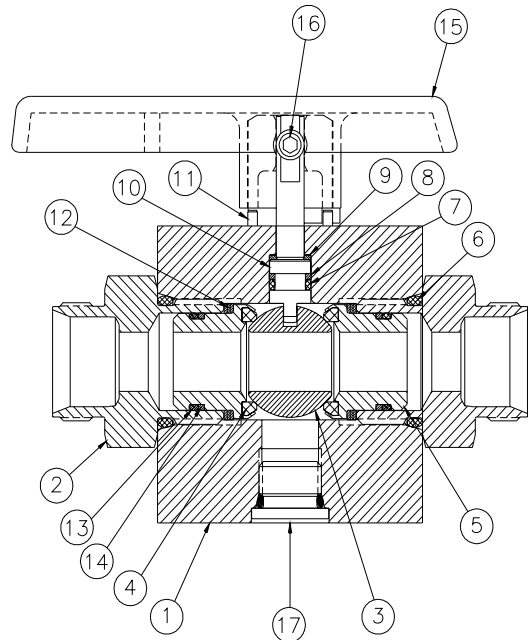

How to Order

The correct part number is easily derived by following the circled number sequence.

Example: 12Z - B12LS2 - V - SS

1
2*
 3
4
5
6

Describes a B12 Series, 2-way, in-line pattern ball valve with 3/4" CPI™ compression end connections for ports 1 and 2, spring loaded PCTFE seats, fluorocarbon rubber seals, and stainless steel body construction.

* Valves with identical port connections for port 1 and 2 require only one designator.

Pressure vs. Temperature

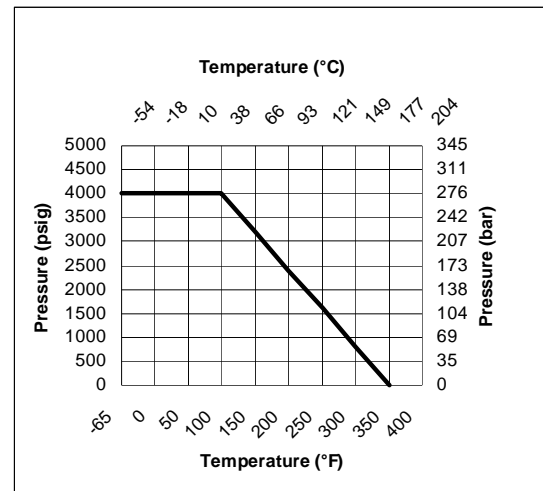

1 Port 1	2 Port 2	3 Valve Series	4 Seat Material	5 Seal Material	6 Body Material
12F - 3/4" FNPT		B12L	S2 - Spring Loaded PCTFE	BN - Buna-N Rubber	SS - Stainless Steel
12A - 3/4" A-LOK®				V - Fluorocarbon Rubber	
12Z - 3/4" CPI™				EPR - Ethylene Propylene Rubber	
16F - 1" FNPT					
16A - 1" A-LOK®					
16Z - 1" CPI™					



Parker Hannifin Corporation
 Instrumentation Valve Division
 2651 Alabama Highway 21 North
 Jacksonville, AL 36265-9681
 Phone: (256) 435-2130
 Fax: (256) 435-7718
www.parker.com/ivd