

Introduction

Parker MB Series Ball Valves, with their rugged compact design, offer positive shut off or directional control of fluids in process, power and instrumentation applications. The unique one piece seat/packing design insures excellent sealing characteristics while accommodating a superior temperature range and cycle life.

These valves are available in two-way and three-way configurations, brass and stainless steel construction, with a wide variety of port connections. Also, all ports are suitable as inlets to full operating pressure of the valve.

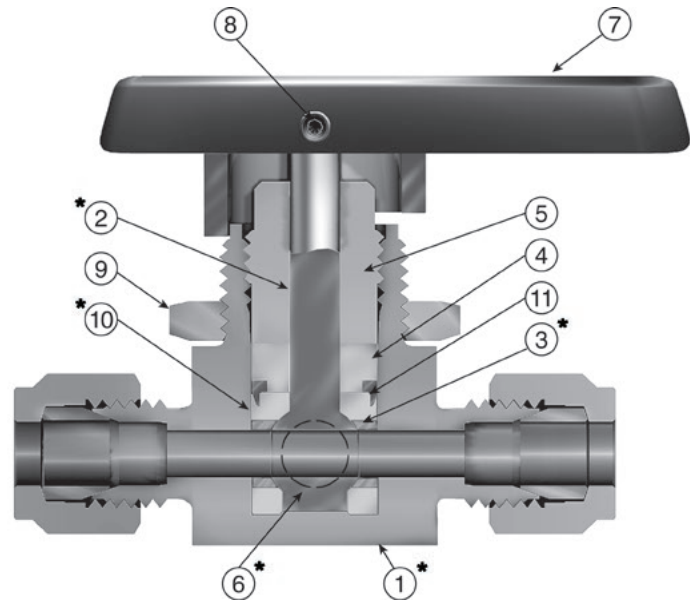

MB

Features

- ▶ One piece seat/packing design
- ▶ Broad temperature range
- ▶ Coated metal inserts
- ▶ One piece stem/ball
- ▶ Wide variety of US Customary and SI ports
- ▶ Panel mountable to 1/4" thickness
- ▶ Bi-directional flow
- ▶ Handle indicates direction of flow
- ▶ Full operating pressure at any port
- ▶ Positive handle stops
- ▶ Color coded handles
- ▶ 100% factory tested
- ▶ Vent option
- ▶ Manual, electric or pneumatic actuation
- ▶ Leak-tight center-off position on three-way valves

Materials of Construction

Item #	Part Description	Stainless Steel	Brass
1	Body	ASTM A 276 Type 316	ASTM B 16 Alloy C36000
2	Stem	ASTM A 276 Type 316	
3	Hollow Insert	316 Stainless Steel	
4	Packing Washer	ASTM B 16 Alloy C36000	
5	Packing Nut	ASTM A 479 Type 316	ASTM B 16 Alloy C36000
6	Solid Insert	316 Stainless Steel	
7	Handle	Nylon 6/6	
8	Set Screw	Stainless Steel	
9	Panel Nut	316 Stainless Steel**	
*10	Seat/Packing	Perfluoroalkoxy (PFA)	
11	Packing Ring	ASTM A 479 Type 316	

* Wetted Parts **Nickel Plated Brass for MB8
Lubrication: Perfluorinated polyether

Specifications

Pressure Rating	3000 psig* (207 bar) CWP - MB6 2500 psig* (172 bar) CWP - MB2/MB4/MB8
Temperature Rating	-65°F to 300°F (-54°C to 149°C)
Orificer	.052" to .406" (1.3mm to 10.3mm)
C_v	.05 to 6.96
Body Materials	Stainless steel and brass
Body Configurations	two-way (in-line and angle) 3-way, 4-way and 5-way
Port Connections	Tube compression (CPI™ / A-LOK®) NPT (Male / Female) BSP, VacuSeal and UltraSeal
Port Size	1/16" to 3/4" and 3mm to 12mm
Seat/Packing	PFA-Perfluoroalkoxy

* Preset from factory to 1000 psig (69 bar) bubble tight service. To achieve higher pressures packing nut must be tightened with Packing Tool MB6X5. Additional details are in INI-243 Installation Instructions. Packing in vented MB Series Ball Valves is factory adjusted for the maximum valve pressure rating of 500 psig (34 bar).

Pressure vs. Temperature

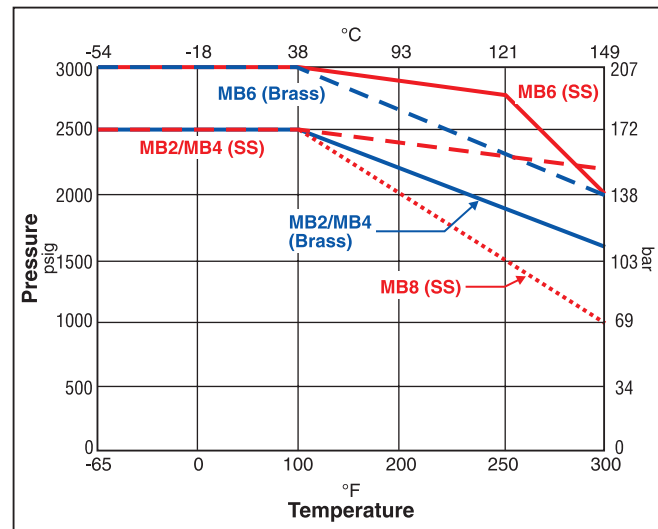

Note: To determine MPa, multiply bar by 0.1

Two-Way In-Line Dimensions, Flow Data

Two-Way In-Line

Vented – In off position the downstream port vents to atmosphere through a hole in the side of the body.

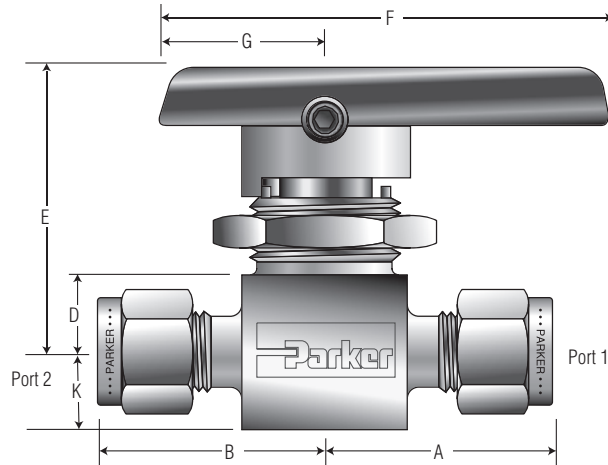

H - Maximum Panel Thickness
I - Panel Hole Diameter
J - Body Width

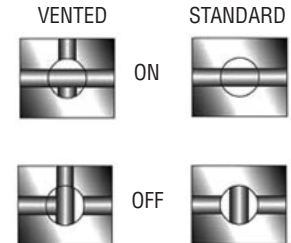

Model shown: 4A-MB6LPFA-SSP

Port Size	Basic Part #	Flow Data				End Connections				Dimensions Inches (mm)							
		Orifice		Cv	X _T *	Port 1	Port 2	A†	B†	D	E	F	G	H	I	J	K
		Inch	mm														
1Z	MB2L	0.052	1.3	0.03	0.46	1/16" CPI™		0.84	0.84	0.34	1.31	1.88	0.75	0.25	0.58	0.58	0.28
1A						1/16" A-LOK®	(21.3)	(21.3)									
2Z		0.093	2.4	0.20	0.42	1/8" CPI™		1.00	1.00								
2A						1/8" A-LOK®	(25.4)	(25.4)									
M3Z		0.086	2.2	0.17	0.43	3mm CPI™		1.00	1.00								
M3A	3mm A-LOK®					(25.4)	(25.4)										
2F	MB4L	0.125	3.2	0.44	0.34	1/8" Female NPT		0.81	0.81	0.34	1.31	1.88	0.75	0.25	0.58	0.58	0.28
4Z						1/4" CPI™	1.12	1.12									
4A						1/4" A-LOK®	(28.5)	(28.5)									
M6Z						6mm CPI™	1.12	1.12									
M6A						6mm A-LOK®	(28.5)	(28.5)									
2Z	MB6L	0.093	2.4	0.18	0.55	1/8" CPI™		1.09	1.09	0.44	1.56	2.37	0.88	0.25	0.77	0.80	0.38
2A						1/8" A-LOK®	(27.7)	(27.7)									
2F		1/8" Female NPT	1.00	1.00													
4M		1/4" Male NPT	1.00	1.00													
4Z		1/4" CPI™	1.19	1.19													
4A		1/4" A-LOK®	(30.2)	(30.2)													
4F		1/4" Female NPT	1.03	1.03													
4M4Z		1/4" Male NPT	1.00	1.19													
4M4A		1/4" Male NPT	1.00	1.19													
4V		1/4" VacuSeal	1.03	1.03													
6Z		3/8" CPI™	1.31	1.31													
6A		3/8" A-LOK®	(33.3)	(33.3)													
M6Z		6mm CPI™	1.19	1.19													
M6A		6mm A-LOK®	(30.2)	(30.2)													
M8Z		8mm CPI™	1.22	1.22													
M8A	8mm A-LOK®	(31.0)	(31.0)														
8A	MB8L	0.406	10.3	10.7	0.16	1/2" A-LOK®		1.94	1.94	0.69	2.39	4.50	1.50	0.38	1.50	1.50	0.69
8Z						1/2" A-CPI™	(49.3)	(49.3)									
8F		1/2" FNPT	1.56	1.56													
12A		3/4" A-LOK®	1.94	1.94													
12Z		3/4" CPI™	(49.3)	(49.3)													
M12A	0.375	9.5	10.7	0.16	12mm A-LOK®		1.96	1.96									
M12Z					12mm CPI™	(49.8)	(49.8)										

* Tested in accordance with ISA S75.02. Gas flow will be choked when $P_1 - P_2 / P_1 = \chi_T$.

† For CPI™ and A-LOK®, dimensions are measured with nuts in the finger tight position.

Dimensions in inches/millimeters are for reference only, subject to change.

Two-Way Angle and Three-Way Dimensions, Flow Data

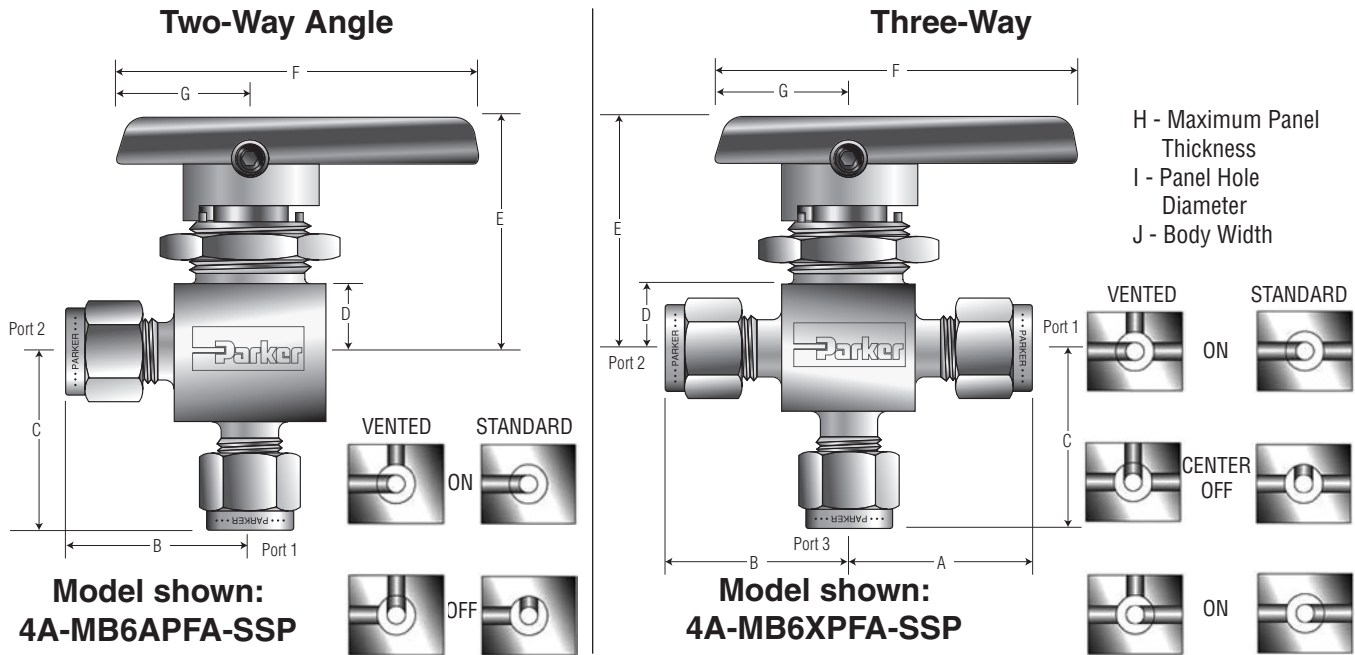

MB

Port Size	Basic Part #	Flow Data				End Connections			Dimensions Inches (mm)									
		Inch	mm	Cv	X _T *	Port 1	Port 2	Port 3 ‡	A †	B †	C	C	E	F	G	H	I	J
1Z	MB2A MB2X	0.052	1.3	0.02	0.58	1/16" CPI™			0.84	0.84	0.81	0.34 (8.6)	1.31 (33.3)	1.88 (47.8)	0.75 (19.1)	0.25 (6.4)	0.58 (14.7)	0.58 (14.7)
1A						1/16" A-LOK®			(21.3)	(21.3)	(20.6)							
2Z		0.093	2.4	0.18	0.48	1/8" CPI™			1.00	1.00	0.97							
2A						1/8" A-LOK®			(25.4)	(25.4)	(24.6)							
M3Z						3mm CPI™			1.00	1.00	0.97							
M3A	0.086	2.2	0.15	0.47	3mm A-LOK®			(25.4)	(25.4)	(24.6)								
2F	MB4A MB4X	0.125	3.2	0.34	0.45	1/8" Female NPT			0.81	0.81	0.81	0.34	1.31	1.88	0.75	0.25	0.58	0.58
4Z						1/4" CPI™			1.12	1.12	1.12							
4A						1/4" A-LOK®			(28.4)	(28.4)	(28.4)							
M6Z						6mm CPI™			1.12	1.12	1.12							
M6A						6mm A-LOK®			(28.4)	(28.4)	(28.4)							
4Z	MB6A MB6X	0.187	4.7	0.70	0.58	1/4" CPI™			1.19	1.19	1.15	0.44 (11.2)	1.56 (39.6)	2.37 (60.2)	0.88 (22.4)	0.25 (6.4)	0.77 (19.6)	0.80 (20.3)
4A						1/4" A-LOK®			(30.2)	(30.2)	(29.2)							
4F						1/4" Female NPT			1.03	1.03	1.03							
									(26.2)	(26.2)	(26.2)							
						1/4" VacuSeal			1.03	1.03	1.03							
4V									(26.2)	(26.2)	(26.2)							
						1/4" CPI™			1.19	1.19	1.03							
4Z4Z4M						1/4" CPI™			(30.2)	(30.2)	(26.2)							
4A4A4M						1/4" A-LOK®			(30.2)	(30.2)	(26.2)							
6Z						3/8" CPI™			1.31	1.31	1.23							
						3/8" A-LOK®			(33.3)	(33.3)	(31.2)							
M6Z						6mm CPI™			1.19	1.19	1.15							
M6A						6mm A-LOK®			(30.2)	(30.2)	(29.2)							
M8Z						8mm CPI™			1.22	1.22	1.18							
						8mm A-LOK®			(31.0)	(31.0)	(30.0)							
8A	MB8A MB8X	0.406	10.3	5.4	0.36	1/2" A-LOK®			1.75	1.75	1.75	0.69 (17.5)	2.39 (60.7)	4.50 (114.3)	1.50 (38.1)	0.38 (9.7)	1.50 (38.1)	1.50 (38.1)
8Z						1/2" A-CPI™			(44.5)	(44.5)	(44.5)							
8F		1/2" Female NPT			1.56	1.56	1.56											
					(39.6)	(39.6)	(39.6)											
12A		3/4" A-LOK®			1.75	1.75	1.75											
12Z	3/4" CPI™			(44.5)	(44.5)	(44.5)												
M12A	0.375	9.5	5.6	0.37	12mm A-LOK®			1.75	1.75	1.75								
M12Z					12mm CPI™			(44.5)	(44.5)	(44.5)								

* Tested in accordance with ISA S75.02. Gas flow will be choked when $P_1 - P_2 / P_1 = x_T$.

‡ Not applicable for the two-way Angle pattern.

† For CPI™ and A-LOK®, dimensions are measured with nuts in the finger tight position.

Dimensions in inches/millimeters are for reference only, subject to change.

How to Order Two-Way In-Line, Two-Way Angle and Three-Way Patterns

The correct part number is easily derived from the following example and ordering chart. The six product characteristics required are coded as shown in the chart.

The following example describes a MB Series, two-way, in-line pattern ball valve with 1/8" CPI™ compression end connections for ports 1 and 2 Inline

Example:

2Z			- MB2LPFA		- SSP	
[] [] []			[] []		[]	
Port 1*	Port 2*	Port 3*	Valve Series	Seat Material	Body Material	
Ports 1, 2 and 3*			Valve Series	Seat Material	Body Material	
1Z	1/16" CPI™	M3Z	3mm CPI™	PFA Perfluoroalkoxy	SSP Stainless Steel (Stainless Steel with Stainless Steel Panel Nut) BP Brass (Brass with Stainless Steel Panel Nut) (Only available in MB 2, 4, 6)	
1A	1/16" A-LOK®	M3A	3mm A-LOK®			
2Z	1/8" CPI™	M3Z	3mm CPI™			
2A	1/8" A-LOK®	M3A	3mm A-LOK®			
2F	1/8" Female NPT	M6Z	6mm CPI™			
4Z	1/4" CPI™	M6A	6mm A-LOK®			
4A	1/4" A-LOK®	M6A	6mm A-LOK®			
2Z	1/8" CPI™	6Z	3/8" CPI™	PFA Perfluoroalkoxy	SSP Stainless Steel (Stainless Steel with Stainless Steel Panel Nut) BP Brass (Brass with Stainless Steel Panel Nut) (Only available in MB 2, 4, 6)	
2A	1/8" A-LOK®	6A	3/8" A-LOK®			
2F	1/8" Female NPT	M6Z	6mm CPI™			
4Z	1/4" CPI™	M6A	6mm A-LOK®			
4A	1/4" A-LOK®	M8Z	8mm CPI™			
4F	1/4" Female NPT	M8A	8mm A-LOK®			
4M	1/4" Male NPT					
4V	1/4" VacuSeal					
8Z	1/2" CPI™	12Z	3/4" CPI™	PFA Perfluoroalkoxy	SSP Stainless Steel (Stainless Steel with Stainless Steel Panel Nut) BP Brass (Brass with Stainless Steel Panel Nut) (Only available in MB 2, 4, 6)	
8A	1/2" A-LOK®	12A	3/4" A-LOK®			
8F	1/2" Female NPT	M12Z	12mm CPI™			
		M12A	12mm A-LOK®			

* Valves with identical port connections for port 1 and port 2 require only one designator.

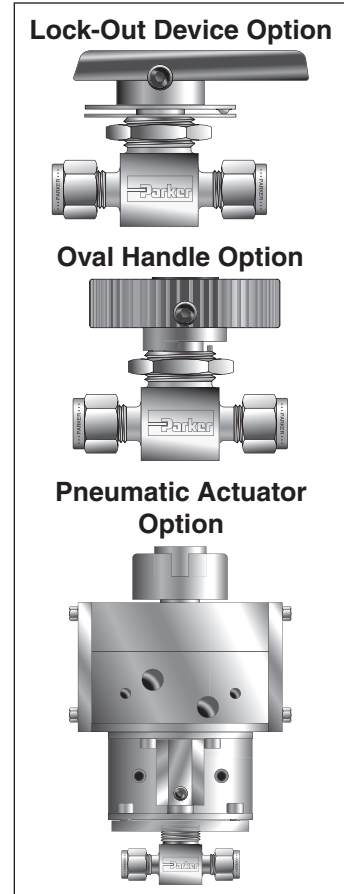

MB

How to Order Options (Two-Way, Angle, and Three-Way)

Lock-Out Devices – Add the suffix **-LD** to the end of the part number to order directly on the valve. **Example:** 2F-MB4LPFA-SSP-LD. For field installation, simply substitute the correct valve series number in the following nomenclature: **LD**-valve series. **Example:** LD-MB6L

Colored Handles – Add the designator corresponding to the correct handle as a suffix to the part number: **W** - white, **B** - blue, **G** - green, **R** - red, **Y** - yellow. **Example:** 4Z-MB6LPFA-SSP-G
NOTE: Not offered in MB8 series.

Stainless Steel Handles – Add the suffix **-ST** to the part number. **Example:** 4F-MB6LPFA-SSP-ST (MB6 series only)

Oval Handles – Add the suffix **-S** to the part number. **Example:** 6Z-MB6APFA-SSP-S. If requesting a colored oval handle, add the suffix **-S**-color designator. **Example:** 6Z-MB6APFA-SSP-S-W
NOTE: MB6 series only.

Vented Valves – Add the designator **V** after the **MB** in the part number for the vent option.
Example: 2Z-MBV2XPFA-SSP.

Oxygen Cleaning – Add the suffix **-C3** to the end of the part number to receive valves cleaned and assembled for oxygen service in accordance with Parker Specification ES8003. **Example:** 4A-MB4LPFA-SSP-C3

Pneumatic Actuators – For detailed actuator information, refer to the [Pneumatic Actuators section](#) of this catalog. For factory assembly, add the actuator part number as the suffix to the valve part number. **Example:** 4A-MB4LPFA-SSP-61AC-2. For field installation, specify the actuator desired. **Example:** 61AC-2. The appropriate mounting hardware may be obtained by adding the valve series and actuator size to the prefix **MK**-. **Example:** MK-MB4L-61

Electric Actuators – For detailed actuator information, refer to the [Electric Actuators section](#) of this catalog. For factory assembly, add the actuator part number as the suffix to the valve part number. **Example:** M6A-MB6XPFA-SSP-71C. For field installation, specify the actuator desired. **Example:** 71C. The appropriate mounting hardware may be obtained by adding the valve series and actuator series to the prefix **MK**-. **Example:** MK-MB6X-70

Dimensions, Flow Data

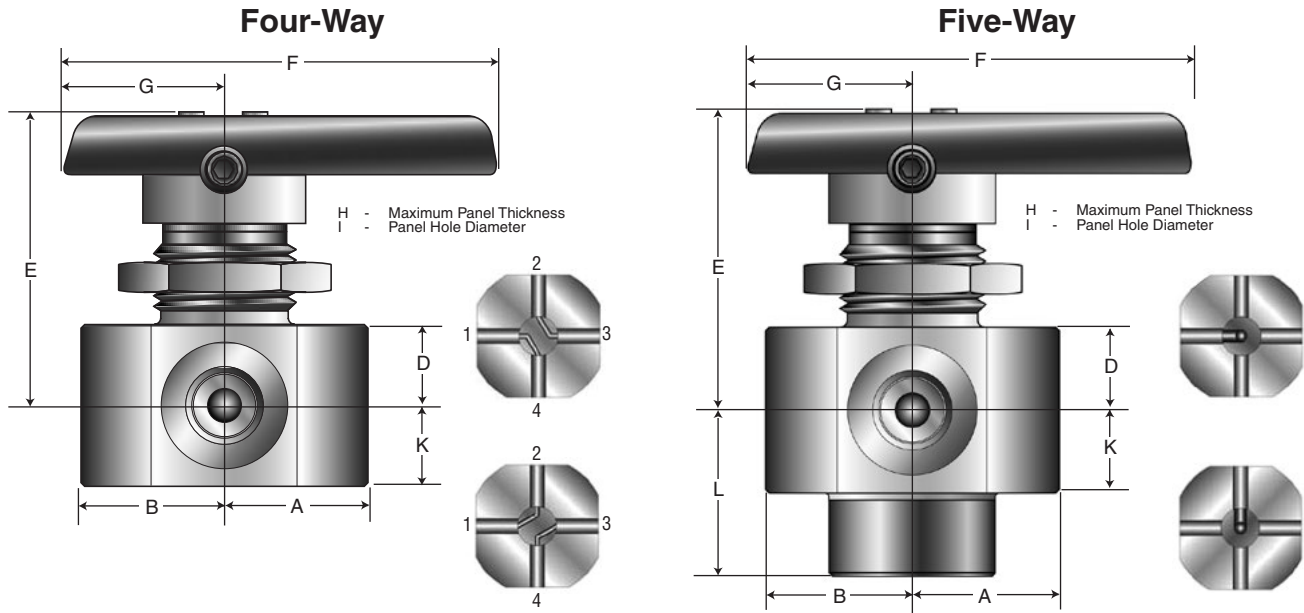

Port Size	Basic Part #	Flow Data				End Connections		Dimensions Inches (mm)									
		Inch	mm	Cv	X _T *	Port 1	Port 2	A†	B†	D	E	F	G	H	I	K	L
2A7	MB6X4	0.063	1.6	0.17	0.16	1/8" Female A-LOK®		0.97	0.97	0.44	1.57	2.37	0.88	0.25	0.77	0.44	
2Z7						1/8" Female CPI™	(24.6)	(24.6)									
2F						1/8" Female NPT	(19.8)	(19.8)									
2A7	MB6X5	0.063	1.6	0.17	0.16	1/8" Inverted A-LOK®		0.97	0.97	0.44	1.57	2.37	0.88	0.25	0.77	0.44	0.97
2Z7						1/8" Inverted CPI™	(24.6)	(24.6)	(24.6)								
2F						1/8" Female NPT	(19.8)	(19.8)	(22.4)								

* Tested in accordance with ISA S75.02. Gas flow will be choked when $P_2 - P_1 / P_1 = x_T$.

† For CPI™ and A-LOK®, dimensions are measured with nuts in the finger tight position.

Dimensions in inches/millimeters are for reference only, subject to change.

How to Order Four-Way and Five-Way Patterns

The correct part number is easily derived from the following example and ordering chart. The four product characteristics required are coded as shown in the chart.

The following example describes a MB-Series four-way pattern ball valve with 1/8" female CPI™ compression end connections for all ports, PFA seat and packing, stainless steel body construction, and a panel mounting nut.

Example:

2Z7	-	MB6X4PFA	-	SSP
End Connection		Valve Series	Seat Material	Body Material
2F	1/8" Female NPT	MB6X4	PFA Perfluoroalkoxy	SSP Stainless Steel (Stainless Steel with Stainless Steel Panel Nut)
2Z7	1/8" CPI™	MB6X5		
2A7	1/8" A-LOK®			

How to Order Options

Colored Handles – Add the designator corresponding to the correct handle as a suffix to the part number: **W** - white, **B** - blue, **G** - green, **R** - red, **Y** - yellow. **Example:** 2F-MB6X4PFA-SSP-R

Stainless Steel Handles – Add the suffix -**ST** to the part number. **Example:** 2A7-MB6XPFA-SSP-ST